

N. G. HERRESHOFF.
Regulators for Steam-Engines.

No. 199,544.

Patented Jan. 22, 1878.

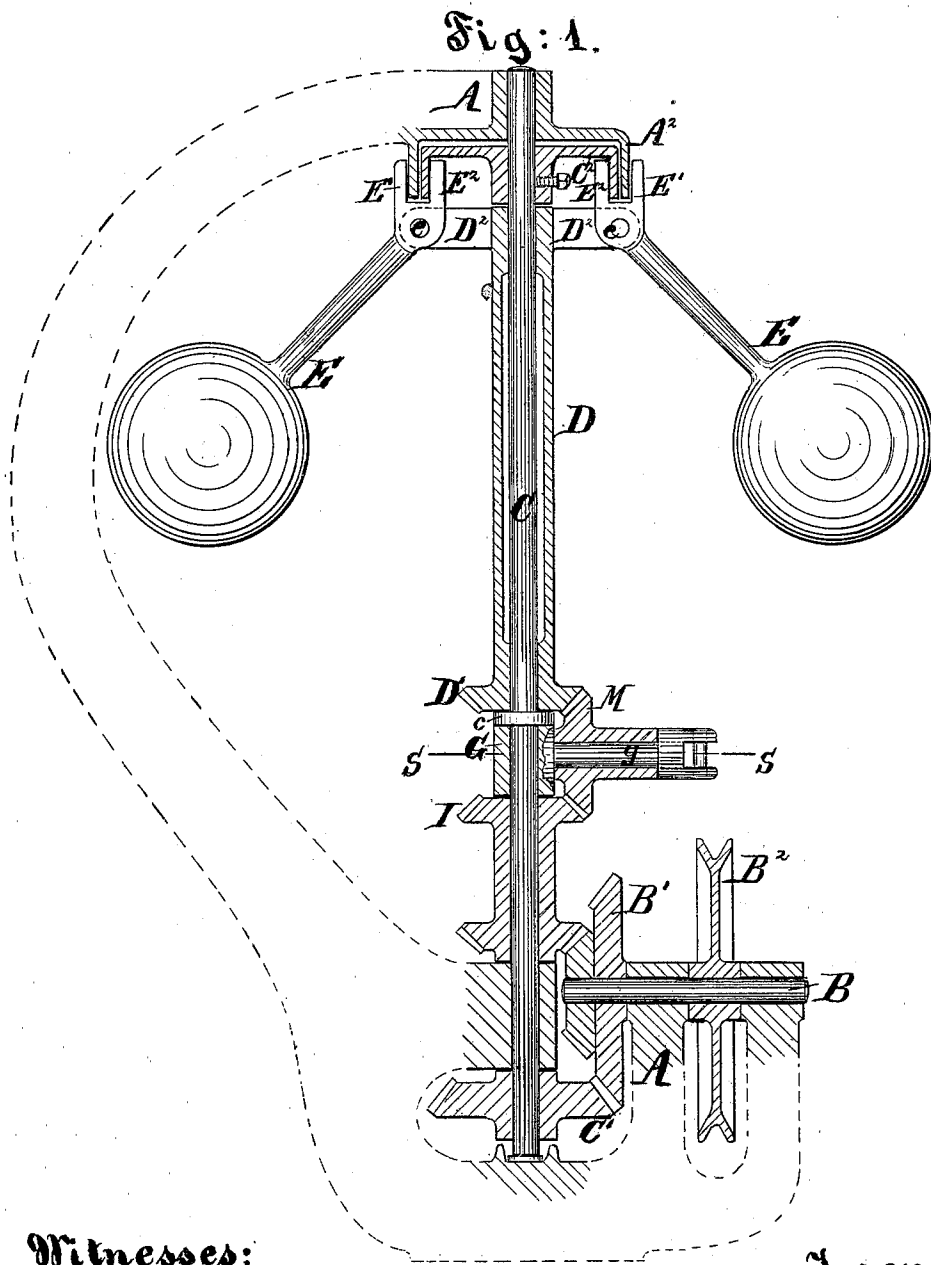

Witnesses:

A. Henry
Chas. C. Stetson

Fig: 2.

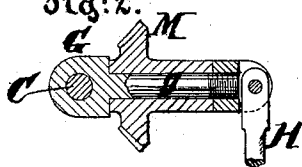

Inventor:

N. G. Herreshoff
his attorney
T. S. Stetson
New York

UNITED STATES PATENT OFFICE.

NATHANIEL G. HERRESHOFF, OF PROVIDENCE, RHODE ISLAND.

IMPROVEMENT IN REGULATORS FOR STEAM-ENGINES.

Specification forming part of Letters Patent No. 199,544, dated January 22, 1878; application filed January 11, 1877.

To all whom it may concern:

Be it known that I, NATHANIEL G. HERRESHOFF, of Providence, in the State of Rhode Island, have invented certain new and useful Improvements relating to Regulators for Steam-Engines and other Motors, of which the following is a specification:

My regulator belongs to that class in which one part is rotated with a uniform velocity and another with a velocity which varies according to that of the engine, water-wheel, or the like. I will describe it as applied to regulate a turbine or other water-wheel by a gate requiring considerable force to move it.

When the wheel goes too quickly the difference in the motion actuates the gate to reduce the supply of water. When the wheel runs too slowly it induces a change in the reverse direction.

I have devised a construction by which the uniform motion is reliably obtained with simple and durable mechanism, and in a manner which allows it to exert a very considerable force.

The following is a description of what I consider the best means of carrying out the invention.

The accompanying drawings form a part of this specification.

Figure 1 is a central vertical section. Fig. 2 is a horizontal section on the line S S in Fig. 1.

Similar letters of reference indicate like parts in both the figures.

A is a fixed frame of cast-iron. B is a horizontal shaft, driven by the water-wheel through a round belt (not represented) running on the pulley B². B¹ is a beveled gear-wheel, meshing into the smaller beveled gear-wheel C¹ keyed on an upright shaft, C, supported in fixed bearings. Suppose the wheel B¹ to have twenty-five teeth, the wheel C¹ may have twenty-two teeth.

C² is a ring fixed on the shaft C, smoothly turned and polished on its inner face. A² is a ring bolted to the fixed framing A and surrounding the revolving ring C².

D is a sleeve fitted tight and easy on the spindle C, and supported by a collar, *c*. Stout arms D² extend out from the sleeve D, and carry heavily-weighted levers E, E, connected

by knuckle-joints *e*. Jaws E¹ E² from each lever E loosely seize both the rings C² and A², adapted to make frictional contact—the jaws E² with the interior of the quick ring C² and the jaws E¹ with the exterior of the fixed ring A². These jaws become effective as the weighted levers E drop below or rise above their correct positions.

While at rest the jaws E² bear strongly. In starting the water-wheel the inertia of the heavy mass on the levers E E may induce a slipping; but the friction due to the strong pressure of the jaws E² against the interior of the revolving ring C² soon generates a nearly similar rotation, but a little more slowly. At this stage of the accelerating motion of the regulator a peculiar action is developed. The force of the frictional contact is lessened. So soon as the velocity becomes sufficient to support the levers E in the right position by centrifugal force the acceleration from the more rapidly revolving ring C² ceases by reason of the pressure of the frictional contact becoming diminished. This follows from the fact that as the levers E swing outward the pressure of the jaws E² against the interior of the ring C² diminishes, and allows the parts to slip freely past each other.

Thus conditioned, the sleeve D soon acquires and persistently maintains a uniform rate of revolution. Ordinarily the jaws E² will press gently against the more quickly revolving ring C², with a tendency to partake of the quicker motion thereof. But if the friction of the spindle C or other cause be more than sufficient to maintain the velocity without any contact of the jaws E² with the quicker ring C², the jaws E¹ will rub slightly against the fixed ring A², and restrain the motion.

For ordinary mills the regulator should be so adjusted that when the engine is running at the proper speed the velocity of the spindle C will be only a little greater than that of the sleeve D. The velocity ratio is found in the ratio of the gear-wheels B¹ and C¹. If they are proportioned as above suggested, the speeds of C and D will be as twenty-five to twenty-two.

For very accurate work, as in regulating a large cotton-mill, there should be but a slight range of motion allowed to the levers E be

tween the pressing of the jaws E^2 against the revolving ring C^2 and the pressing of the jaws E^1 against the fixed ring A^2 .

Having by these means obtained a reliable and uniform motion of the sleeve D , with its heavy attachments, which, by their great inertia, are capable of developing much force when required, my means for regulating the water-wheel thereby are as follows:

A loose sleeve, G , is fitted on the spindle C , free to rotate in either direction. An arm, g , extends outward therefrom, and to it is joined a wire or rod, H , extending away horizontally and connected to the gate, (not represented,) so that its being moved will quicken or retard the water-wheel, as will be readily understood. A bevel-wheel, M , mounted loosely on this arm g , gears below into a beveled gear-wheel, I , which is mounted loosely on the spindle C , and receives motion from the driving-shaft B through the train of gears represented, so that its rate of revolution corresponds rigorously with that of the water-wheel at every moment. The wheel M also gears above into a beveled gear-wheel, D^1 , fixed on the lower end of the uniformly-revolving sleeve D , running in the opposite direction to I .

While the velocity of the water-wheel is exactly right these two wheels I D^1 run in opposite directions at precisely the same rate, and the wheel M turns idly between them. But the moment the water-wheel or corresponding engine runs too quickly, and I gains upon D^1 , the wheel M indicates the difference by moving the arm g and the connecting-rod H to shut off the water. When, a few seconds later, the work runs too slowly, the wheel M is traversed the other way by the wheel D^1 , and the arm g now moves the wire or rod H to give more water. Thus the mill soon attains its proper speed and maintains it.

The governor may be worked with some success with only one of the revolving arms and weights E , or with a greater number than the two shown; but I prefer the employment of two, arranged to directly balance each other, as represented.

I claim as my improvement in regulators—

1. An impelling frictional surface, in combination with the weights revolved thereby, the parts being so combined that the frictional force becomes less as the weights revolve more rapidly, substantially as and for the purposes herein set forth.

2. In combination with the spindle C , sleeve D , levers E , and suitable connections to the motor, the friction-rings C^2 and the corresponding jaws E^2 on the loaded levers E , adapted to serve as herein specified.

3. In combination with a centrifugal governor, and with provisions for allowing the motor to run ahead or behind, as specified, a stationary friction-piece, A^1 , adapted to restrain the motion of the governor when in excess, as herein specified.

4. The beveled gears B^1 I C^1 and pulley B^2 , in combination with the wheel M , controlling the freely-turning arm g , and with the revolving parts C D , having motions, the one uniform and the other varying with that of the engine, as herein specified.

5. The combination of revolving weights, impelling frictional means, retarding frictional means, and connecting mechanism for controlling the motor, according as it runs ahead or behind, as herein specified.

In testimony whereof I have hereunto set my hand this 4th day of January, 1877, in the presence of two subscribing witnesses.

NATHL. G. HERRESHOFF.

Witnesses:

M. E. CHAPPOTIN,
S. DE V. CHAPPOTIN.