

(No Model.)

2 Sheets—Sheet 1.

J. B. F. HERRESHOFF.
COPPER SMELTING FURNACE.

No. 273,840.

Patented Mar. 13, 1883.

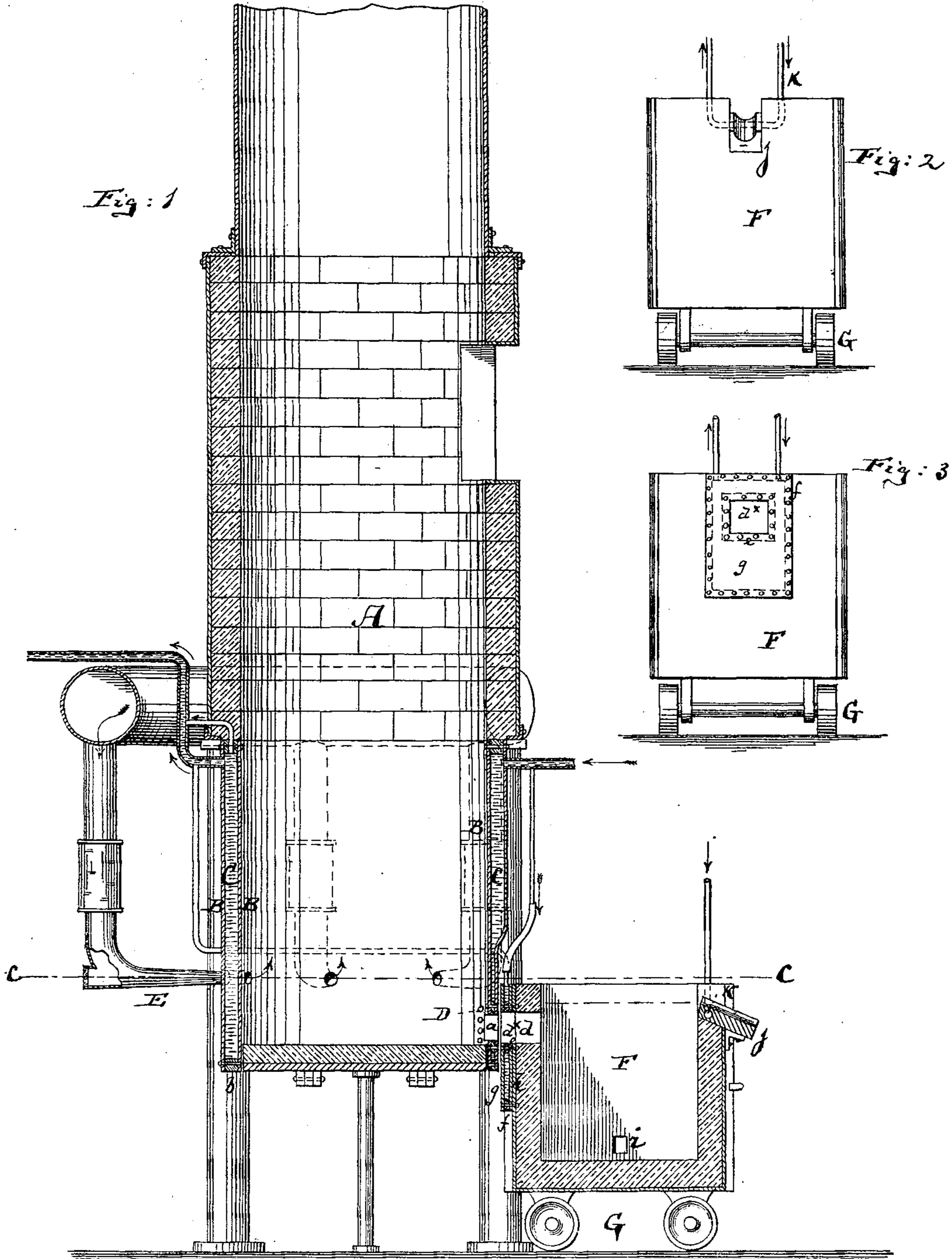

Witnesses:
 Henry F. Parker.
 John C. Dunbridge

Inventor:
 J. B. F. Herreshoff
 By his Attorneys
 Prinsen & Betts

(No Model.)

2 Sheets—Sheet 2.

J. B. F. HERRESHOFF.

COPPER SMELTING FURNACE.

No. 273,840.

Patented Mar. 13, 1883.

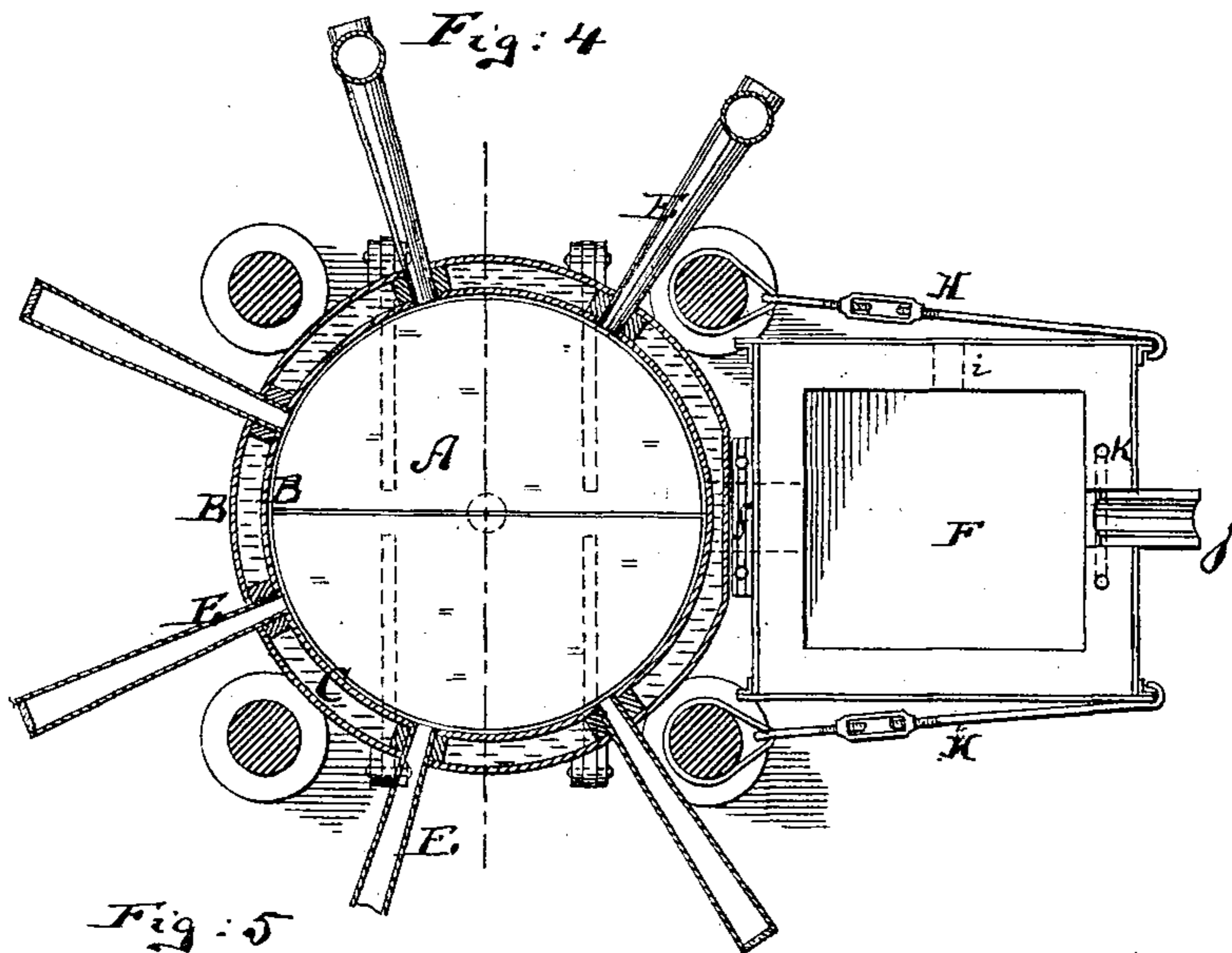
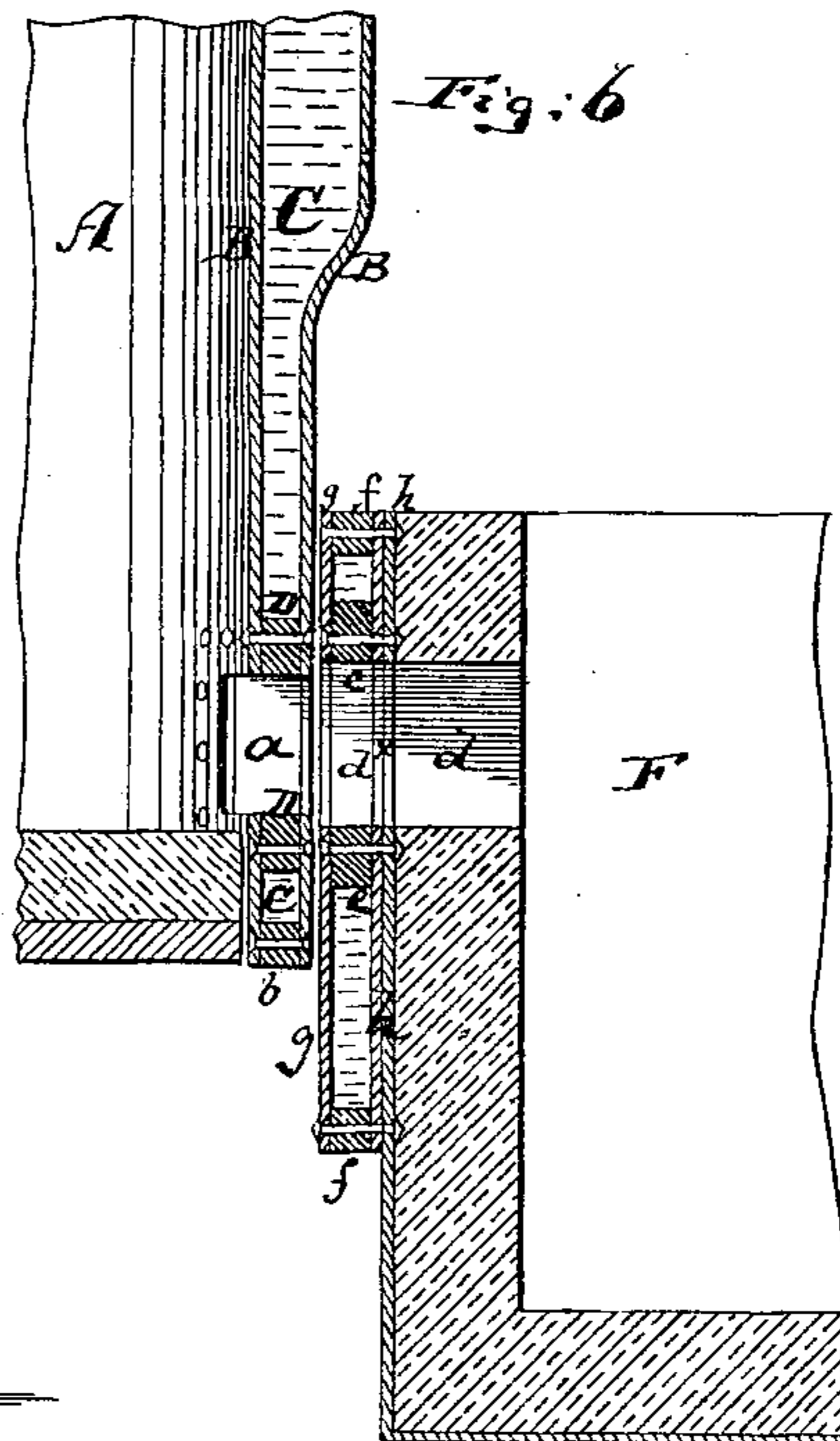
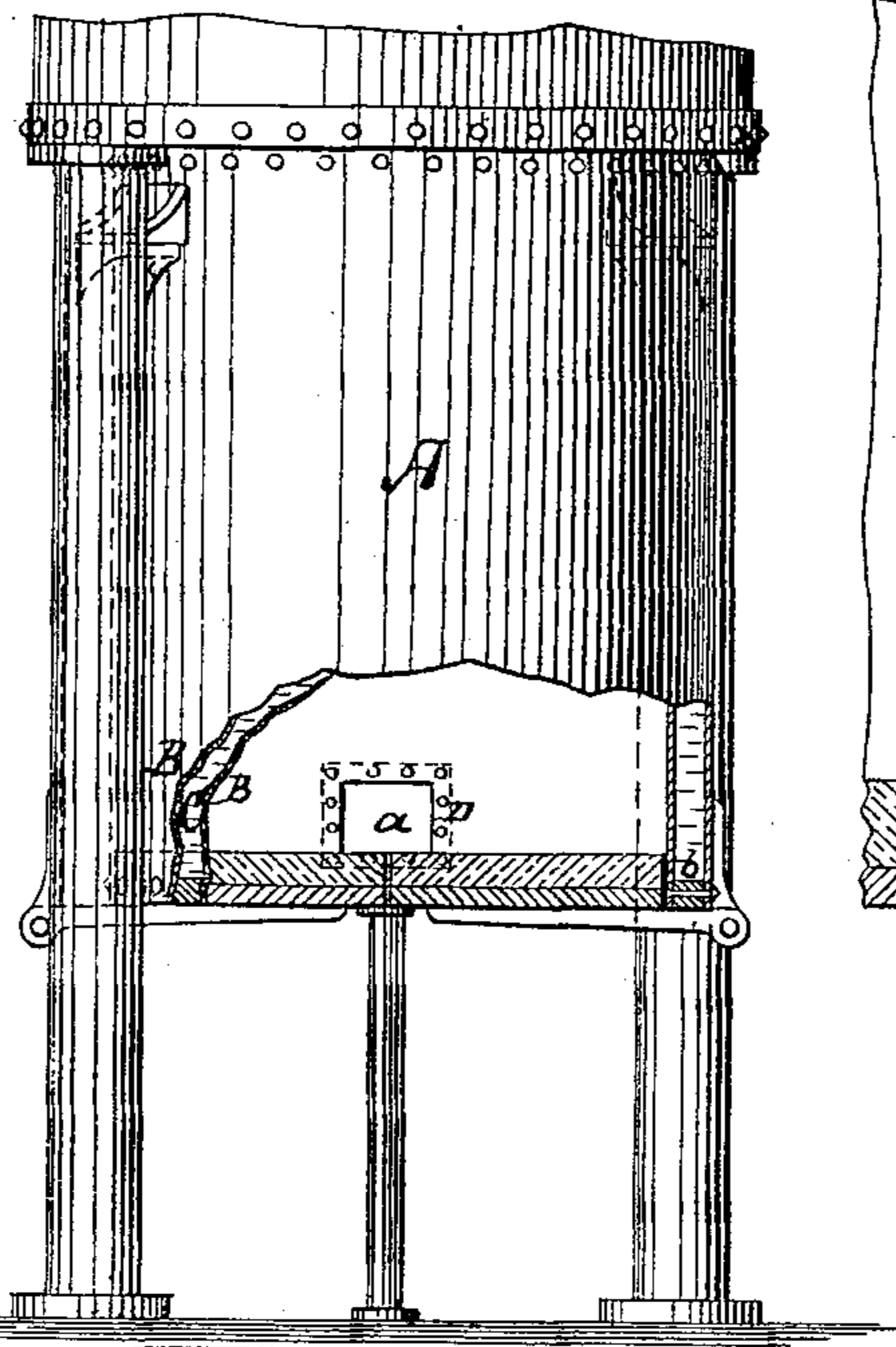

Fig. 5



Witnesses:
Henry W. Parker.
John C. Tunbridge

Inventor:
J. B. F. Herreshoff.
by his attorneys
Brisson & Betts

UNITED STATES PATENT OFFICE.

JOHN B. F. HERRESHOFF, OF BROOKLYN, NEW YORK, ASSIGNOR TO HIMSELF, AND GEORGE H. NICHOLS AND WILLIAM H. NICHOLS, BOTH OF NEW YORK, N. Y.

COPPER-SMELTING FURNACE.

SPECIFICATION forming part of Letters Patent No. 273,840, dated March 13, 1883.

Application filed May 5, 1882. (No model.)

To all whom it may concern:

Be it known that I, JOHN BROWN FRANCIS HERRESHOFF, of Brooklyn, in the county of Kings and State of New York, have invented
5 a new and Improved Copper-Smelting Furnace, of which the following is a specification.

Figure 1 is a vertical central section of my improved copper-smelting furnace. Fig. 2 is an outer end view, and Fig. 3 an inner end
10 view, of the well that is used in connection with said furnace. Fig. 4 is a horizontal section of the furnace on the line *cc*, Fig. 1. Fig. 5 is an elevation, partly in section, of the lower part of the furnace; and Fig. 6 is a detail ver-
15 tical section, on an enlarged scale, through the slag-outlet of the furnace.

The object of this invention is to provide a furnace for smelting copper or the like with means for allowing the proper outflow of the
20 matte and slag into a well or receiver without risking too rapid destruction of the walls through which said matte and slag escape, and likewise without unduly chilling the escaping mass.

Another object is to permit due continuity of process by providing for the removal, when full or worn out, of the well or receiver, and substitution for the same of another well or receiver, instead of making the latter a definite
25 attachment to the furnace.

My invention consists in attaching a water-jacket, composed of an inner metal frame, an outer metal frame, and an outer plate, to the outside of the well or receiver, said water-
35 jacket forming a continuity of the inlet-opening of the well. The well is made movable, being placed on wheels, and is provided with a spout near its upper end.

Other features of improvement will more
40 fully appear from the following description:

In the drawings, the letter *A* represents a suitable furnace for smelting copper or analogous substances. The lower part of this furnace is built up of double metal walls *B*, which
45 contain between them a water-chamber, *C*. Through the lower part of this water-chamber is made the aperture *a*, for the discharge of the molten mass from the furnace. This aperture *a* is formed by placing a thick iron frame,
50 *D*, into the water-jacket *C*, which frame is

bolted or riveted to the walls of the jacket *C*, and forms the outer wall of the opening *a* and the inner wall to the water-jacket *C*, as clearly shown in Fig. 6. In practice this frame *D*
55 should be of such size that the hole *a* will measure six by six inches, and that the iron of which the frame *D* is composed should measure about one by two inches in thickness. These measurements are intended for a fur-
60 nace which in its main smelting portion is about six to eight feet high, four to five feet in diameter, and made of two iron cylinders, *B B*, of which the ends are riveted to a two-by-two wrought-iron ring, *b*.

The tuyeres *E E*, entering through the wa-
65 ter-jacket *C*, are shown in Fig. 4.

The discharge-opening *a* of the furnace communicates with the receiving-opening *d* of the well or receiver *F*. This receiver is a metallic
70 box lined on the inner side with fire-brick and placed on wheels or rollers *G*. That side of the well which faces the furnace *A* carries a water-jacket which is formed by two iron frames, *e* and *f*, and by metallic face-plates *g* and *h*. This water-jacket is bolted or other-
75 wise fastened to the well *F*, on the outer side thereof, in such manner that the space *d'*, bounded by the inner frame, *e*, constitutes a prolongation of the opening *d*, and is likewise
80 in line with the aperture *a*, as clearly shown in Fig. 6. Water is fed into the space between the frames *e* and *f* through suitable pipes. The inner frame, *e*, is of the thickness substantially of the frame *D*.

In practice the molten contents of the fur-
85 nace will flow through the passage *a d' d* into the well *F*, which is placed close to the furnace, and anchored to the same, by preference, by means of screw-bolts *H*, (shown in Fig. 4,) and as the molten matter passes through the
90 said channel *a d' d* it will heat the iron frames *D* and *e*; but these frames, being in contact, on their outer edges, with the water, will not be rapidly destroyed by the heat, and yet they are of such thickness that where they
95 are in contact with the molten mass they will not cause the same to be unduly chilled, although they are in contact with water. In other words, the water-jackets protect these iron frames *D* and *e* from rapid destruction by
100

the heat, and yet the iron frames are of such thickness that they protect the molten matte and slag from undue chilling by the water.

Whatever greater or less space for leakage
5 may exist between the frames D and e will be luted by the matte that leaks into such space, and thus continuity of the passage to the well will be established and the well itself protected from rapid destruction by the heated
10 mass. When the well is full or is to be repaired it can readily be moved away from the furnace on its wheels and its place occupied by another well of like construction, so that the continuity of the process going on in the
15 furnace need not be interrupted.

Although I have shown the frame D placed into a water-jacket that embraces the entire lower part of the furnace, it is nevertheless clear that the invention is also applicable to
20 furnaces which are not entirely surrounded by a water-jacket, in which case the frame D, surrounded by a partial water-jacket substantially like that shown on the body of the well F, may be built into the brick furnace.

25 The well F has a lower discharge-opening, *i*, and an upper spout, *j*, which spout is cooled by a pipe, *k*, that carries water through it.

Throughout, the furnace above described is calculated to protect the parts that would otherwise be exposed to rapid destruction by
30 contact with the heated contents from such destruction, and I have found in practice that the arrangement of double water-jacket or interposed water-jacket between the well and
35 jacketed furnace makes the well last very

much longer than does the ordinary well heretofore used.

I do not claim placing an annular water-jacket between the stationary and the rotary parts of a puddling-furnace, nor the mere use of
40 water-jacketed outlet-openings for furnaces.

So far as the well itself is concerned, it can be advantageously used in a furnace having no water bath.

I claim—

1. The combination of a smelting-furnace
45 having water-jacket around the discharge-opening *a*, near its lower end, with the removable well or receiver F, having inlet-opening *d* near its upper end, and with a water-jacket
50 having opening *d*^{*}, attached to said well and forming a continuous passage with opening *d*, so that it will be interposed between the well and the water-jacket on said furnace, and continuous therewith when said well is placed
55 against said furnace, substantially as described.

2. The combination of a smelting-furnace, having tap-hole *a*, with a movable well, F, having inlet-opening *d*, which is continuous with
60 said tap-hole *a* when the well is in position, said well being provided with a vertical water-jacket on its outer side, said water jacket forming a passage, *d*['], contiguous to and in line with the inlet-opening *d* of the well, substantially as described.

JOHN BROWN FRANCIS HERRESHOFF.

Witnesses:

WILLIAM H. C. SMITH,
WILLY G. E. SCHULTZ.