

(No Model.)

N. G. HERRESHOFF.  
VALVE GEAR FOR STEAM ENGINES.

No. 280,311.

Patented June 26, 1883.

Fig: 2.

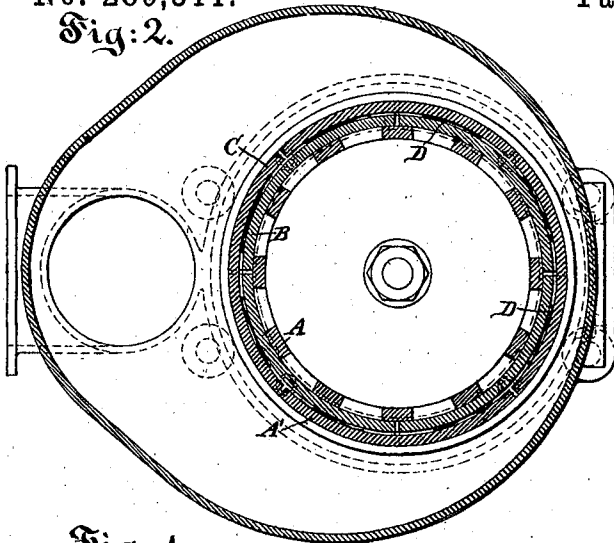

Fig: 1.

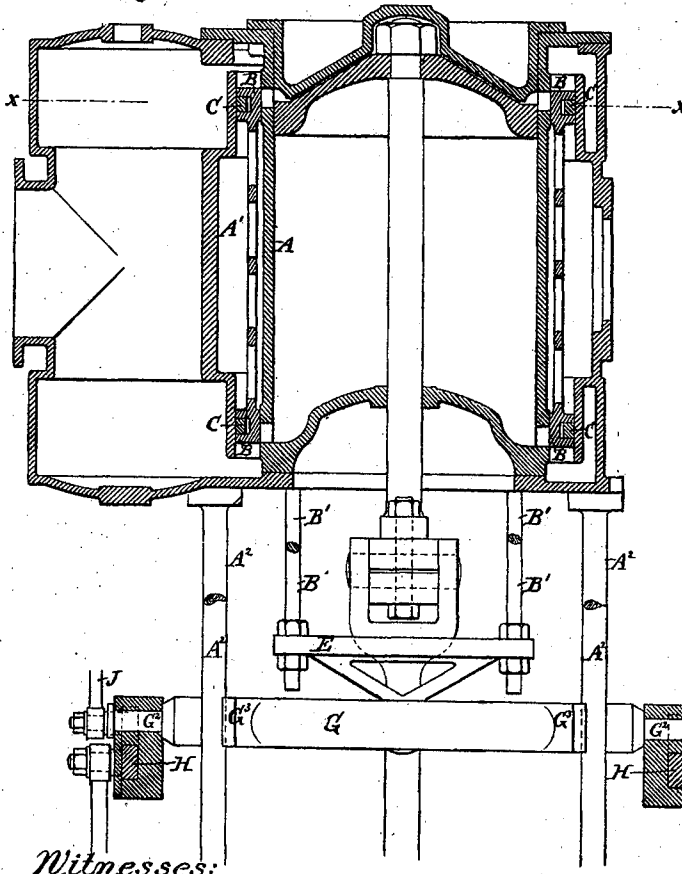

Fig: 3.

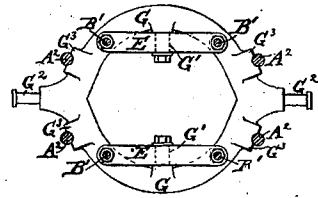

Fig: 4.

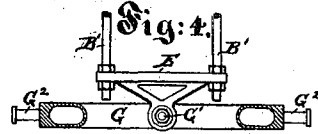
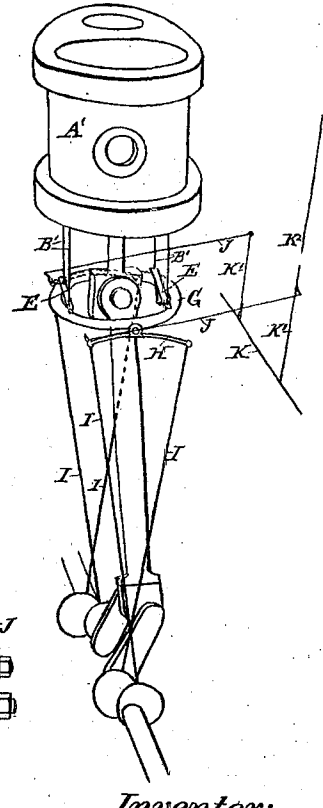

Fig: 5.



Witnesses:  
No. F. Boyle.  
A. H. Gentry

Inventor:  
Nathaniel G. Herreshoff.  
By his Atty. Thomas D. Weston.

# UNITED STATES PATENT OFFICE.

NATHANIEL G. HERRESHOFF, OF BRISTOL, RHODE ISLAND, ASSIGNOR TO  
THE HERRÉSHOFF MANUFACTURING COMPANY, OF RHODE ISLAND.

## VALVE-GEAR FOR STEAM-ENGINES.

SPECIFICATION forming part of Letters Patent No. 280,311, dated June 26, 1883.

Application filed March 12, 1883. (No model.)

*To all whom it may concern:*

Be it known that I, NATHANIEL G. HERRESHOFF, of Bristol, in the county of Bristol and State of Rhode Island, have invented certain  
5 new and useful Improvements in Valve-Gear for Steam-Engines, of which the following is a specification.

I allow, by ample annular ports extending around the cylinder, unusually liberal passages  
10 for the admission and escape of the steam, adapting the engine to work efficiently at very high speeds.

The invention consists in the details of the mechanism fully set forth below. It is intended  
15 more especially for small swift steamers with screw-propellers, but may be of advantage in a great variety of situations.

The following is a description of what I consider the best means of carrying out the inven-  
20 tion.

The accompanying drawings form a part of this specification.

Figure 1 is a central vertical section through the cylinder of an upright engine. Fig. 2 is  
25 a horizontal section on the line  $x x$  in Fig. 1. The piston is not sectioned, but drawn in plan. Fig. 3 is a plan view of certain portions on a smaller scale, and Fig. 4 is a vertical section  
30 of the same. Fig. 5 is a general perspective view of the working parts of the engine.

Similar letters of reference indicate like parts in all the figures.

The drawings show the novel parts with so much of the ordinary parts as is necessary to  
35 show their relation thereto.

I finish at both ends of the cylinder, on the exterior thereof, an even surface, with a port at each end through such surface, extending quite  
40 around, except that it is broken by "bridges" to maintain the continuity of the metal. An annular valve incloses the cylinder at each end, fitting steam-tight upon the cylindrical seats thus provided. A rigid cylindrical casing is  
45 fitted exterior to the valve at each end, a tight joint being maintained therewith by a packing-ring. The annular valve at one end is rigidly connected to the annular valve at the other end. The whole is made in sections. A spring-pack-  
50 ing is interposed between the sections of the valve and the sections of the packing-ring. There are as many valve-stems as there are sections of the valve-ring. Means are provided

for working the whole uniformly, and to allow for slight mal-adjustments and variations of expansion, &c.

Referring to the figures, A is the cylinder, and A' the external concentric casing. B B  
55 are the annular valves, and C the packing-rings therefor. D are the springs, interposed between C and B. The two annular valves B  
60 B are connected by rigid lattice-work. The valves and the connecting-lattice are divided longitudinally along four lines, so as to make four sections. The packing-rings C are corre-  
65 spondingly divided, but arranged so that they break joints with the valves. There are four valve-stems, B'—one valve-stem for each section of the valve. The valve-stems are attached  
70 by twos to a pair of levers or eveners, E, which turn on pins G', set in a large ring, G, which is moved up and down by two separate but equal link-motions attached to the trunnions  
75 G<sup>2</sup>. The ring G is made of stout tubing, so as to be stiff with little weight, and is guided by bearings G<sup>3</sup>, which embrace smoothly-finished upright posts A<sup>2</sup> of the framing which forms  
part of the supporting-framing for the cylinders, as will be readily understood.

I employ two sets of what is known as the "Stevenson link-motion," or, more briefly,  
80 link-motion. H is one of the links of the style sometimes known as "single" or "solid"—that is, not slotted, but curved to the proper radius, and nicely finished. It is rocked by  
85 eccentric-rods I, leading each from a separate eccentric set on the main shaft, as will be understood. It is shifted by a link, J. There  
90 are two of these links H, and two of the links J, actuated by two arms, K', from a shaft, K, mounted in suitable fixed bearings, and turned  
by a hand-lever, K<sup>2</sup>, equipped with dogs for engaging with notches on a quadrant, in the ordinary long-approved manner. The turning  
of the single lever K<sup>2</sup> shifts both links H.

The eveners E perform an important function in equalizing the action of the two link-  
95 motions on the four valve-stems, and consequently on all parts of the valve under all conditions. The sections of the valve B, having a length equal to the working part of the cyl-  
100 nder, and being well tied together by the sections of the packing-rings C, work practically as one, and open and close the annular ports uniformly all around.

The two sets of valve-gear, one for each of the trunnions G<sup>2</sup>, should be equal; but in case of any mal-adjustment or inequality, the ring G, with its levers H, serves, like the gimbaling of a compass, to allow for the inequality, so that all the valve-stems will be actuated equally. With any reasonably good work the action of the two sets of valve-gear will be approximately equal. It is therefore necessary to allow only a small amount of rocking to the levers H. I have arranged the levers so that when they have rocked a little way one end or the other will bear firmly on the ring G, thus preventing any further rocking. In case of the breakage of the connection of one of the valve-stems, or some analogous failure of a part, the engine may continue to work, though imperfectly, by the valve being worked by the other three stems. The limited amount of the rocking is of advantage in facilitating the work under such conditions.

The making of the valves B and packing-ring C in sections allows them to open and close a little. This accommodates any variation in expansion and contraction of the valves and cylinder. It also performs an important function when there is water in the cylinder, which must find a vent as the piston approaches the end of the cylinder, after the valve has closed, and has commenced to cushion the exhaust. If the valves were continuous annular rings, there would be no vent. Being sections, they may yield by the compression of the springs D, and allow a liberal vent all around for the discharge of the water. Each joint between the sections of the valves B is arranged to come on a bridge dividing the ports, so that there is no leakage of steam into or out of the cylinder through such joints. The joints may be formed in any ordinary or approved manner, and guarded by a tongue or covering-plate against the passage of steam vertically across the valve. The packing-rings C are similarly equipped.

Modifications may be made in the forms and proportions of the details. Parts may be used with some success without the whole. Instead of spring-packing, steam-packing may be used.

I claim as my invention—

1. The annular valves B, made in sections, adapted to allow the valve to expand and contract, in combination with a cylinder, A, having annular ports, with bridges; the joints in the valve being opposite the bridges, as herein specified.

2. The cylinder A, having annular ports, with bridges, the outer casing, A', concentric thereto, the valves B for the two ends rigidly united, and formed in sections, as shown, in combination with each other and with the packing-rings C and springs D, arranged for joint operation, as herein specified.

3. In a steam-engine, the two links H H, actuated independently, but similarly, in combination with each other, and with suitable connections to annular valves B B, working as shown, relatively to a single cylinder, A, having annular ports, substantially as herein specified.

4. In a steam-engine having annular valves B extending around the cylinder A, as shown, the four or more valve-stems B', connected gimbal-wise, so that the actuating force is applied equally to all, as herein specified.

5. The rocking levers or eveners E E, in combination with the ring G and valve-stems B', arranged to limit the extent of the rocking motion, substantially as and for the purpose herein specified.

In testimony whereof I have hereunto set my hand, at Bristol, Rhode Island, this 9th day of March, 1882, in the presence of two subscribing witnesses.

NATHL. G. HERRESHOFF.

Witnesses:

C. H. KINYON,  
J. F. SMITH.