

No. 729,170.

PATENTED MAY 26, 1903.

J. B. F. HERRESHOFF.
ORE ROASTING FURNACE.

APPLICATION FILED JAN. 16, 1903.

NO MODEL.

2 SHEETS—SHEET 1.

Fig. 1.

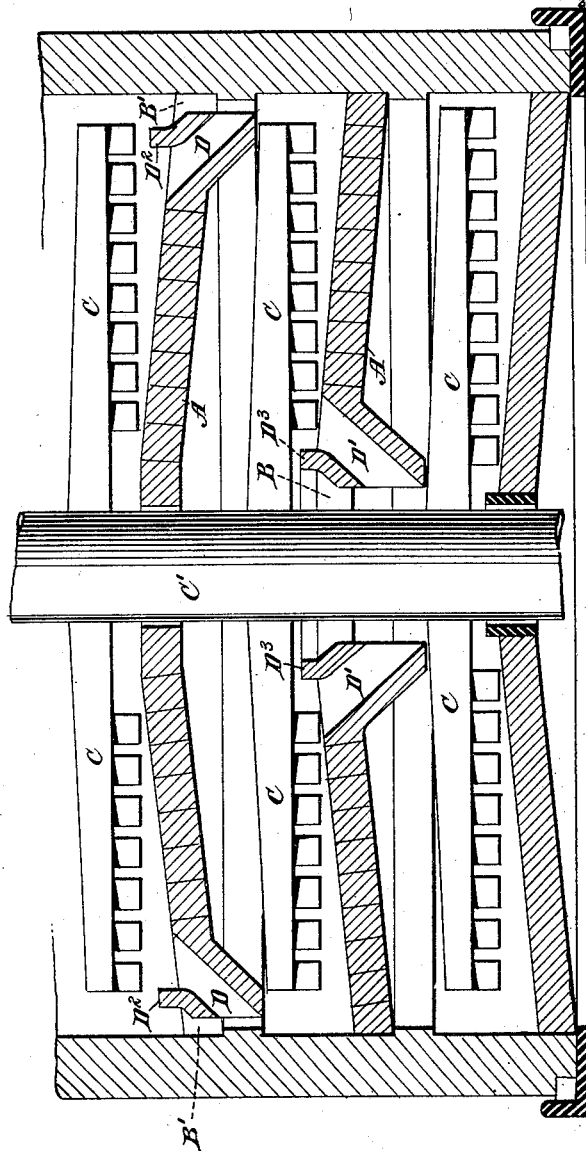
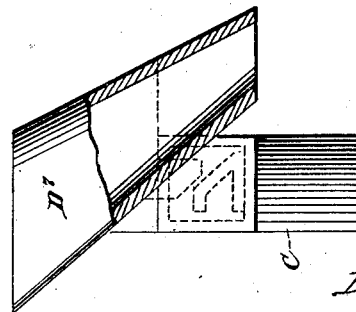

Fig. 4.



WITNESSES:
J. A. Neukirch
John Lotka

INVENTOR
J. B. F. Herreshoff
 BY
Brian Smith
 ATTORNEYS

No. 729,170.

PATENTED MAY 26, 1903.

J. B. F. HERRESHOFF.
ORE ROASTING FURNACE.
APPLICATION FILED JAN. 16, 1903.

NO MODEL.

2 SHEETS—SHEET 2.

Fig. 3.

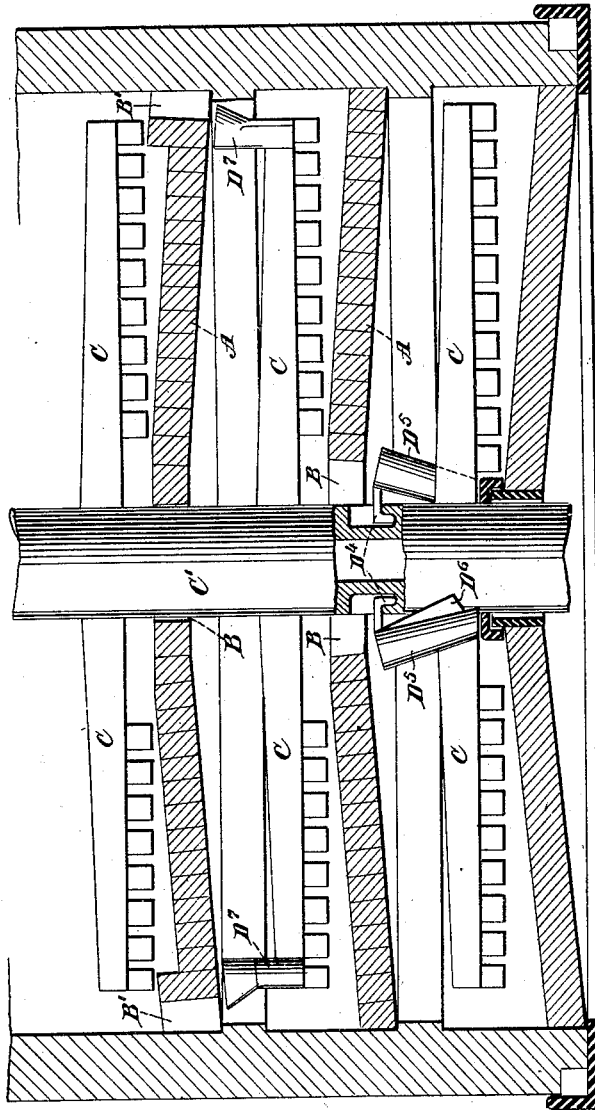
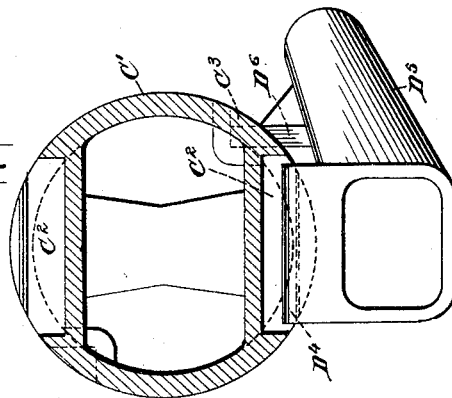

Fig. 2.



WITNESSES:

J. A. Schleicher
John Lott

INVENTOR

J. B. F. Herreshoff
BY
Brinley Smith
ATTORNEYS

UNITED STATES PATENT OFFICE.

JOHN B. F. HERRESHOFF, OF NEW YORK, N. Y.

ORE-ROASTING FURNACE.

SPECIFICATION forming part of Letters Patent No. 729,170, dated May 26, 1903.

Application filed January 16, 1903. Serial No. 139,258. (No model.)

To all whom it may concern:

Be it known that I, JOHN B. F. HERRESHOFF, a citizen of the United States, and a resident of the borough of Manhattan, city, county, and State of New York, have invented certain new and useful Improvements in Ore-Roasting Furnaces, of which the following is a specification.

My invention relates to ore-roasting furnaces, and particularly to furnaces of the character of that shown in United States Letters Patent No. 616,926, of January 3, 1899. In furnaces of this character it has been found that in case the ore particles are very fine they are liable to be carried upward by the gases, so that a portion of the ore is lost. The purpose of my present invention is to overcome this drawback and to reduce to a minimum the action of the upward current of gas upon the ore, so that said current of gas may carry away very little of the ore, if any.

The invention will be fully described hereinafter and the features of novelty pointed out in the appended claims.

Reference is to be had to the accompanying drawings, in which—

Figure 1 is a vertical section showing the lower part of an ore-roasting furnace provided with my invention. Fig. 2 is a sectional plan illustrating a portion of my invention. Fig. 3 is a sectional elevation showing another form of my invention; and Fig. 4 is a detail view showing one of the rakes and a spout carried thereby.

The class of furnaces to which my invention relates comprises a series of superposed shelves or partitions upon which the ore is adapted to rest temporarily, the partitions being provided with openings alternately at the center and at the periphery for the purpose of allowing the ore to pass from one partition to the next partition below. In combination with the stationary shelves there are employed rotary rakes for the purpose of crowding the material gradually toward the said discharge-openings. Thus one rake will crowd the material inward, while the next rake below will be arranged to crowd the material outwardly. Now, according to the present invention, instead of simply providing openings in the partitions or shelves, as

has been done heretofore, there are employed spouts extending from one shelf toward the other and arranged to so conduct the ore that it will be exposed but very little to the upward current of gas. These spouts may be arranged in various manners, and in the drawings I have illustrated several typical arrangements.

A indicates the shelves; B, the openings at the center; B', the openings at the periphery, and C the rakes, which are secured to a shaft C' and which have teeth so inclined that upon a rotation of the rakes the ore will be fed toward the openings of the shelves. So far the construction is substantially the usual one.

According to one form of my invention (shown in Fig. 1) the spouts D D' are stationary, being secured to the shelves A or forming part thereof. In order that the material may reach the spouts only and may not be crowded beyond the same, a raised ridge or flange D² D³, extending continuously around, may be provided on that side of the spout which is opposite to that from which the ore is supplied. By the flange D³ the ore is prevented from dropping through the central opening B and there being exposed to the current of gas, which might carry the ore dust or fine particles away. The ore passes through the spouts D D' only, and as these spouts are practically outside the path of the gas the gas-current will interfere but very little, if at all, with the downward movement of the ore. The spouts D D' will be preferably practically continuous or annular.

In another form of my invention the spouts instead of being stationary are carried so as to rotate with the rakes C. The spouts at the inner or central portion of the apparatus can be carried directly by the shaft C', and, if desired, the connection may be made detachable, as by means of a lip D⁴ on the spout D⁵, which lip engages a pocket C² on the shaft, and a pin D⁶, which engages a slot C³ of the shaft, Fig. 2. It will be understood that the rakes feed the material inward toward the central opening B; but such material is discharged only adjacent to the innermost tooth of the rake, and the spout D⁵ is arranged immediately below the innermost portion of the rake, so that the spout is al-

ways in position to receive the material which the rake crowds toward the central opening B. In this case also it will be observed that the spout gives the ore a path protected from the influence of the upward current of gas.

The rotary spouts D', which are intended for cooperation with the peripheral openings B', are, as shown in Fig. 3, carried by the outer portions of the respective rakes C. These spouts also perform the function of keeping the ore together and preventing small particles of the ore from being carried away by the gas-current.

My invention in any one of the forms shown enables an apparatus of the class described to be efficiently used with very fine crushed ore, and thus considerably increases the usefulness of the roasting-furnace.

Various modifications may be made without departing from the nature of my invention.

What I claim, and desire to secure by Letters Patent, is—

1. A roasting-furnace having superposed shelves apertured for the passage of the ore, and means for crowding the ore toward the apertures of the shelves, in combination with spouts extending between the shelves and adapted to direct the ore on its way from one shelf to the next shelf below in such a manner as to protect the ore from the influence of the draft.

2. A roasting-furnace comprising superposed shelves apertured for the passage of the ore, and means for crowding the ore toward the apertures of the shelves, in combination with spouts arranged to rotate between the shelves in receiving relation to the apertures thereof.

3. A roasting-furnace comprising superposed shelves apertured for the passage of the ore, and rotary rakes for crowding the ore toward the apertures of the shelves, in combi-

nation with spouts connected to rotate with the rakes so as to always preserve the same position relatively thereto, said spouts being arranged between the shelves and in receiving relation to the apertures thereof.

4. A roasting-furnace comprising superposed shelves apertured for the passage of the ore, and rotary rakes for crowding the ore toward the apertures of the shelves, in combination with spouts secured to said rakes and arranged between adjacent shelves in receiving relation to the apertures of the upper shelf.

5. A roasting-furnace comprising superposed shelves apertured alternately at the center and at the periphery, means located between the shelves for crowding the material alternately inward to the central aperture and outward to the peripheral apertures, and spouts located between the shelves and arranged to direct the ore on its way from one shelf to the next shelf below in such a manner as to protect the ore from the influence of the draft.

6. A roasting-furnace comprising superposed shelves apertured alternately at the center and at the periphery, a shaft extending through the central apertures of the shelves, rakes secured to said shaft between the shelves and arranged to crowd the material alternately inward and outward, spouts secured to said shaft below the central apertures of the shelves, and spouts carried by the rakes and disposed below the peripheral apertures of the shelves.

In testimony whereof I have signed my name to this specification in the presence of two subscribing witnesses.

JOHN B. F. HERRESHOFF.

Witnesses:

W. H. NICHOLS, Jr.,
EUGENE EBLE.