

Jan. 11, 1927.

1,613,890

L. F. HERRESHOFF

SAIL BOAT

Filed Dec. 11, 1925

3 Sheets-Sheet 1

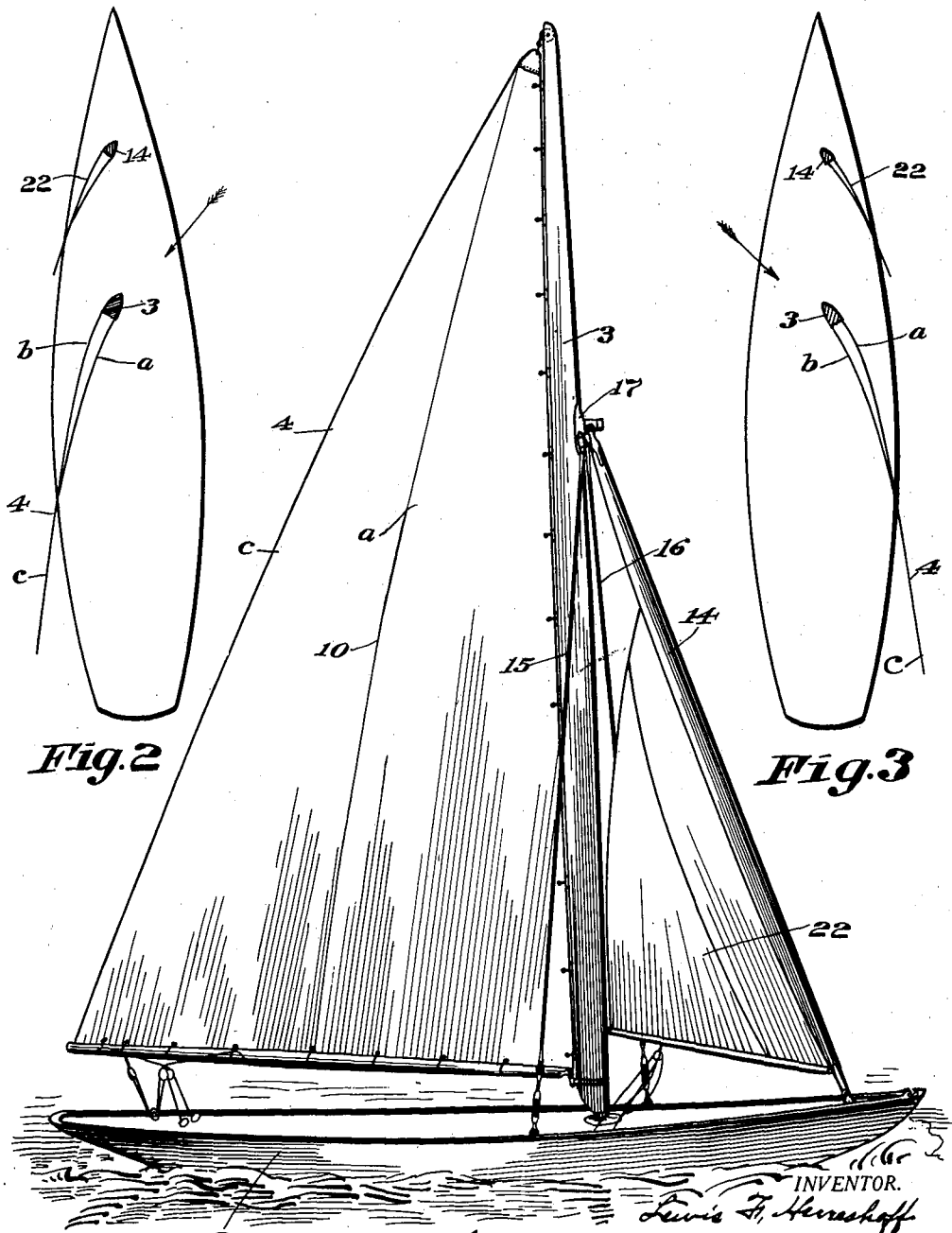

Fig. 2

Fig. 3

Fig. 1

BY

INVENTOR.
Lewis F. Herreshoff

J. H. McCurdy
his ATTORNEY.

Jan. 11, 1927.

L. F. HERRESHOFF

1,613,890

SAIL BOAT

Filed Dec. 11, 1925

3 Sheets-Sheet 2

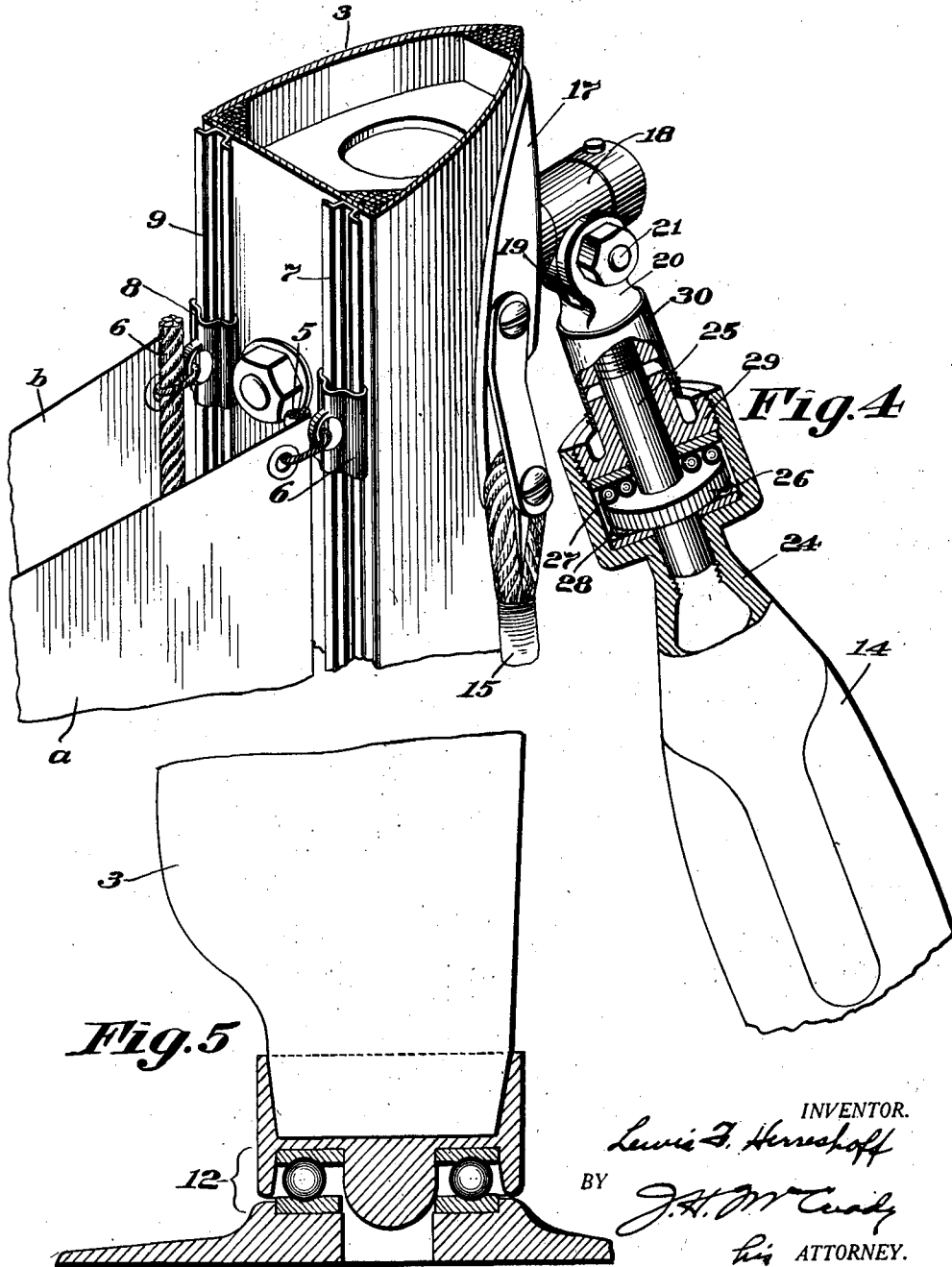

INVENTOR.
Lewis F. Herreshoff
BY *J. H. McCurdy*
his ATTORNEY.

Jan. 11, 1927.

1,613,890

L. F. HERRESHOFF

SAIL BOAT

Filed Dec. 11, 1925

3 Sheets-Sheet 3

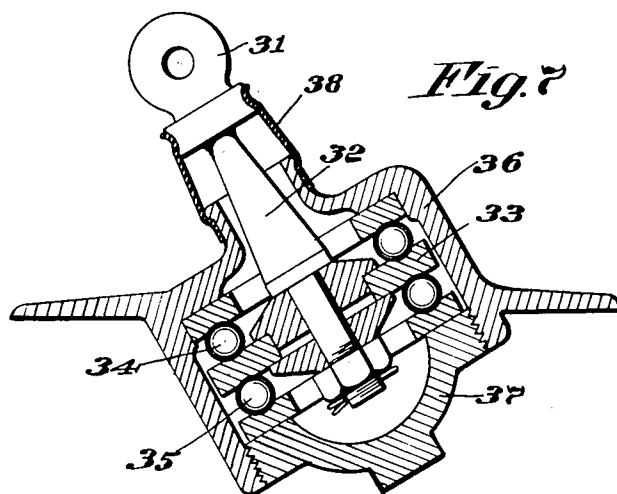
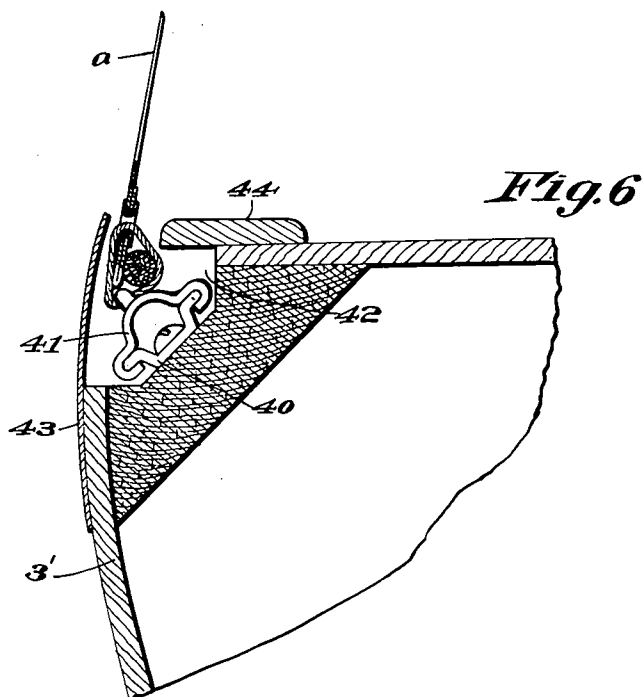

INVENTOR.
Lewis F. Herreshoff
BY *J. H. McCurdy*
his ATTORNEY.

UNITED STATES PATENT OFFICE.

LEWIS FRANCIS HERRESHOFF, OF BRISTOL, RHODE ISLAND.

SAILBOAT.

Application filed December 11, 1925. Serial No. 74,728.

This invention relates to various types of sailing craft, hereinafter referred to as sail boats, and is more especially concerned with such craft designed for racing purposes.

5 The invention has for its chief object to improve the mast and sail construction of sail boats with a view to increasing their efficiency.

The nature of the invention will be readily understood from the following description when read in connection with the accompanying drawings, and the novel features will be particularly pointed out in the appended claims.

15 In the drawings—

Figure 1 is a perspective view of a sail boat embodying this invention;

20 Figs. 2 and 3 are diagrammatic views, partly in cross-section, showing the position of the sails and mast in tacking;

Fig. 4 is a cross-sectional perspective view illustrating certain details of the mast construction and the means for securing the stays and sails thereto;

25 Fig. 5 is a vertical, cross-sectional view through the step bearing for the mast;

Fig. 6 is a horizontal cross sectional view showing another method of fastening the sail to the mast; and

30 Fig. 7 is a vertical cross-sectional view through the bearing at the lower end of the spar which serves as a stay for the mast.

Referring first to Fig. 1, the hull of the boat there shown is indicated at 2, the mast at 3, and the main sail at 4. This sail is divided at a point some distance aft and the mast 3 into two vertically disposed sections or wings *a* and *b*, Figs. 1 to 4, inclusive. These wings extend the entire height of the sail, and their forward edges are spaced apart and secured to the mast at opposite sides thereof. Referring to Figs. 1 and 4 it will be seen that the forward edge of the wing *a* is tied or lashed at intervals to slides 6 and also to the luff rope 5, the slides 6 being arranged to run freely on a track or rail 7 which is secured to the after side of the mast 3. The wing *b* is similarly secured to slides 8 which run on a track 9. As the wings *a* and *b* extend aft they converge, as indicated in Figs. 2 and 3, and their after edges are joined to the forward edge of another wing *c* along the line or seam indicated at 10, Fig. 1, the three parts *a*, *b* and *c* constituting the main sail.

By dividing the sail as above described,

and joining the forward edges of the two sections or wings thereof to the mast so that they are substantially flush with the opposite sides of the mast, a substantially smooth stream line surface is presented to the action of the wind, the eddying of the wind around the mast is eliminated, and a more efficient arrangement is provided.

In furtherance of this result, the mast also preferably is given a stream line shape. That is, it has a relatively thin forward edge, as shown in Figs. 2 and 3, and the opposite sides diverge from each other as they extend aft so that in cross-section it resembles the bow portion of a boat. Such a construction offers less resistance to the wind, and cooperates with the divided sail in presenting to the wind a smooth substantially continuous surface uninterrupted by obstructions or irregularities around which the wind would eddy.

The mast may either be made solid, as indicated in Figs. 2 and 3, or hollow, as shown in Fig. 4.

In order to further increase the efficiency of the sail and mast, I prefer to mount the mast so that it can swing with the sail about an axis extending longitudinally thereof. For this purpose the mast is supported in a step bearing which preferably is of the ball type as shown at 12 in Fig. 5, and it is held in its upright position by stays or shrouds which permit the mast to turn in the bearing 12. The mast is supported in its fore and aft position by a forestay consisting of a spar 14, Figs. 1 and 4, which connects the mast with the bow of the boat and acts both as a strut or compression member and also as a tension member. Shrouds or stays 15 and 16, Fig. 1, support the mast laterally. Any suitable means may be used for connecting the spar and stays to the mast, but as shown they are all secured to a fitting 17, Figs. 1 and 4, which is bolted to the mast. The two stays 15 and 16 are secured to shackles provided on the opposite sides of this fitting. A member 20 is secured to the upper end of the spar 14 and is pivoted, by means of a bolt 21, to an ear or lug 19 projecting from a sleeve 18 which pivots on the bolt that secures the fitting 17 in place. This construction supports the mast securely in its operative position, and at the same time permits the mast to swing freely with the sail in tacking, or as its position changes due to the sail adjusting itself to the wind.

Since the spar 14 is adapted to take both compression and tension, it effectually supports the mast in its fore and aft position and eliminates the necessity for a back stay.

5 It should be observed that the mast is so supported that the axis about which it pivots is located at the forward side or leading edge of the mast. Consequently, the mast automatically takes such a position, as it
10 swings with the sail, that its thin forward edge is always presented to the wind.

The spar 14 supports a jib 22 which is made like the main sail 4, and it preferably is made of the same cross sectional form as
15 the mast 3. In order to permit this spar to swing with the jib 22, in tacking, it is provided at its opposite ends with ball bearing swivels so that it can swing freely about its longitudinal axis. The upper swivel is
20 shown in Fig. 4 and comprises a fitting 24 secured directly to the upper end of the spar 14. The part 20, above referred to, is secured on the upper end of a post or shaft
25 having a disk 26 rigidly secured thereto or integral therewith, and this disk rides on upper and lower sets of balls 27 and 28, respectively, all of these parts being mounted within the fitting 24. A sleeve 29 has a
30 head which is threaded into the upper end of the part 24 and may be adjusted to afford the desired amount of play or clearance in the ball bearings. Entrance of water into the bearing is prevented by a sleeve 30 of rubber, or other flexible waterproof material,
35 which is secured to the parts 20 and 29, as clearly shown in Fig. 4.

A similar construction, shown in Fig. 7, is employed at the lower end of the spar 14. This end of the spar is provided with a
40 slotted metal tip designed to be pivoted to an ear 31 which is formed on the upper end of a swivel post 32. This post is secured rigidly to a bearing disk or plate 33 which runs between upper and lower sets of balls
45 34 and 35, respectively, these balls and the disk being mounted in a suitable housing 36 which is designed to be bolted to the deck or fore timbers of the boat. A cap 37 is threaded into the housing 36 and may be
50 adjusted to give the ball bearings 34 and 35 the desired amount of play. Water is excluded from the housing by a rubber sleeve 38 similar to the sleeve 30 above described. The swivels permit the spar to turn freely
55 with the jib as the latter swings, this movement taking place without interfering in any way with the function of the spar as a strut or stay for the mast.

As above stated, both the main sail and
60 the jib and the mast and spar which support them, are shaped to present smooth and substantially continuous surfaces to the action of the wind. The mounting of the mast and spar so that they can pivot freely
65 about axes extending longitudinally of them

enables them to swing with their sails as the sails adjust themselves to the wind so that the stream line effect is always maintained regardless of the position of the sails. These advantages are very important in racing
70 where it is necessary to utilize every factor that will increase the speed of the boat and where the difference between the winning and losing of a race may involve only a fraction of a second in time.
75

Another construction which may be used in securing the two sections of the main sail to the mast 3 is illustrated in Fig. 6 where the track 40 for the slides 41 to which the wing *a* is secured, is set into a groove
80 42 formed in a corner of the mast 3'. This groove is partly closed by plates 43 and 44 secured, respectively, to one side and the rear of the mast so that only a relatively narrow slot is provided through which the
85 edge of the sail *a* projects.

While I have herein shown and described the best embodiment of my invention that I have so far devised, it will be evident that the invention may be embodied in other
90 forms without departing from the spirit or scope thereof.

Having thus described my invention, what I desire to claim as new is:

1. In a sail boat, the combination of a
95 mast, said mast having a relatively thin forward edge and increasing in cross-sectional width as it extends aft, a sail comprising two upright wings spaced apart at their forward edges and joined together at a considerable distance aft from the mast, and means for connecting the forward edges of said wings to the mast approximately flush with the opposite sides thereof, said means permitting the raising and lowering of the sail
100 relatively to the mast.

2. In a sail boat, the combination of a mast, said mast having a relatively thin forward edge and increasing in cross-sectional width as it extends aft, a sail comprising
110 two upright wings spaced apart at their forward edges and joined together at a considerable distance aft from the mast, two tracks secured to the after side of said mast at opposite edges thereof, and slides running on
115 said tracks and securing the forward edges of said wings to the respective tracks.

3. In a sail boat, the combination of a mast, a sail supported by said mast, a step bearing supporting said mast, means for holding said mast in its fore and aft position comprising a spar connecting said mast with the forward part of the boat, a pivotal connection between the forward side of said mast and the upper end of said spar, and
120 stays fastened to said connection and supporting the mast laterally.

4. In a sail boat, the combination of a mast, a sail supported by said mast, a step bearing supporting said mast, a spar con-
125
130

necting said mast with the forward part of the boat and holding the mast in its fore and aft position, swivel connections at the opposite ends of said spar, and a jib supported by said spar.

5 5. In a sail boat, the combination of a mast of stream line cross-sectional form, and a sail supported by said mast and adapted to be raised or lowered relatively thereto, said
10 sail comprising two wings, the forward edges of which are spaced apart and fastened to the mast at opposite sides thereof, said wings converging as they extend aft and being joined together at their after
15 edges.

6. In a sail boat, the combination of a mast of stream line cross-sectional form, said mast having a thin forward edge, a sail supported by said mast at the after surface
20 thereof, and means for supporting said mast for free pivotal movement about an axis extending therealong forwardly of the center of the mast, whereby the mast can swing freely about said axis with the sail and will
25 automatically present its thin forward edge to the wind.

7. In a sail boat, the combination of a mast of stream line cross-sectional form, said mast having a thin forward edge, a sail supported by said mast, a step bearing supporting said mast for free pivotal movement about an axis extending therealong forwardly of the center of the mast, and a spar holding said mast in its fore and aft position.

8. In a sail boat, the combination of a mast of stream line cross-sectional form, said mast having a thin forward edge, a sail supported by said mast, a step bearing supporting said mast for free pivotal movement about an axis extending longitudinally of the mast, whereby the mast can swing automatically about said axis with the sail, a spar connecting said mast with the forward part of the boat and holding the mast in its fore and aft position, said spar being of stream line cross-sectional form, a jib supported by said spar, and swivel bearing supporting said spar for movement about an axis extending longitudinally thereof and permitting it to swing about said axis with the jib.

9. In a sail boat, the combination of a mast of stream line cross-sectional form, a sail supported by said mast and adapted to be raised or lowered relatively thereto, said sail comprising two wings, the forward edges of which are spaced apart and fastened to the mast at opposite sides thereof, said wings converging as they extend aft and being joined together at their after edges, said mast having a thin forward edge, and means for supporting said mast for free pivotal movement about an axis extending therealong whereby the mast can swing freely about said axis with the sail and will automatically present its thin forward edge to the wind.

LEWIS FRANCIS HERRESHOFF.

Certificate of Correction.

Patent No. 1,613,890.

Granted January 11, 1927, to

LEWIS FRANCIS HERRESHOFF.

It is hereby certified that error appears in the printed specification of the above-mentioned patent requiring correction as follows: Page 1, line 36, for the word "and" read *of*; and that the said Letters Patent should be read with this correction therein that the same may conform to the record of the case in the Patent Office.

Signed and sealed this 8th day of March, A. D. 1927.

[SEAL.]

M. J. MOORE,
Acting Commissioner of Patents.