

Oct. 6, 1970

L. F. HERRESHOFF

3,532,446

SLIDING SEAL AND VALVE FOR RECIPROCATING PUMP

Filed April 4, 1967

2 Sheets-Sheet 2

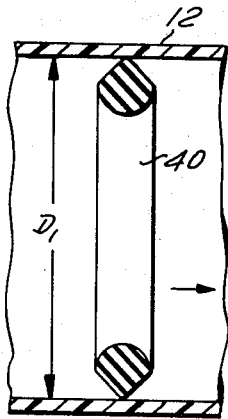

FIG. 3

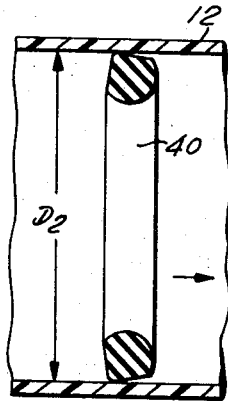

FIG. 4

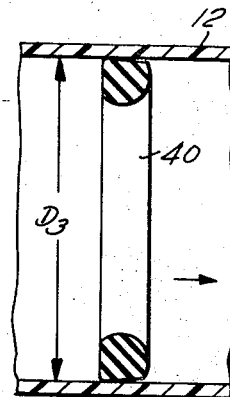

FIG. 5

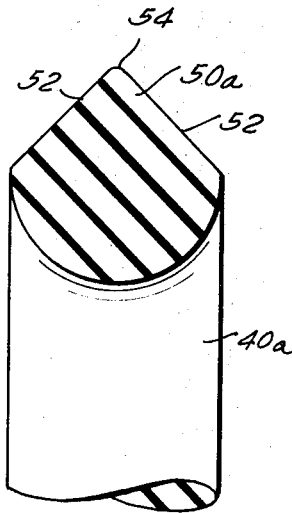

FIG. 6

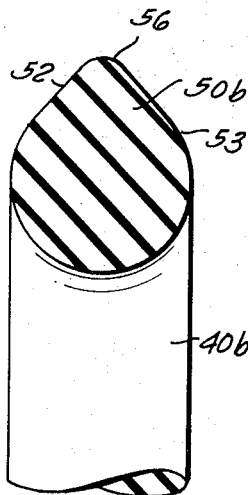

FIG. 7

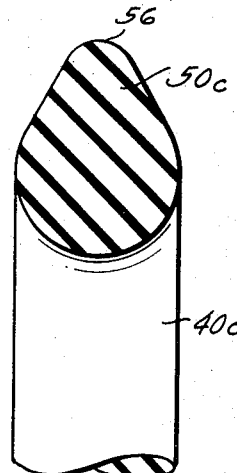

FIG. 8

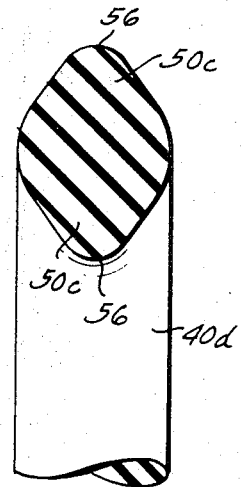

FIG. 9

L. Francis Herreshoff
INVENTOR

BY Michael S. Strickland

ATTORNEY

Oct. 6, 1970

L. F. HERRESHOFF

3,532,446

SLIDING SEAL AND VALVE FOR RECIPROCATING PUMP

Filed April 4, 1967

2 Sheets-Sheet 1

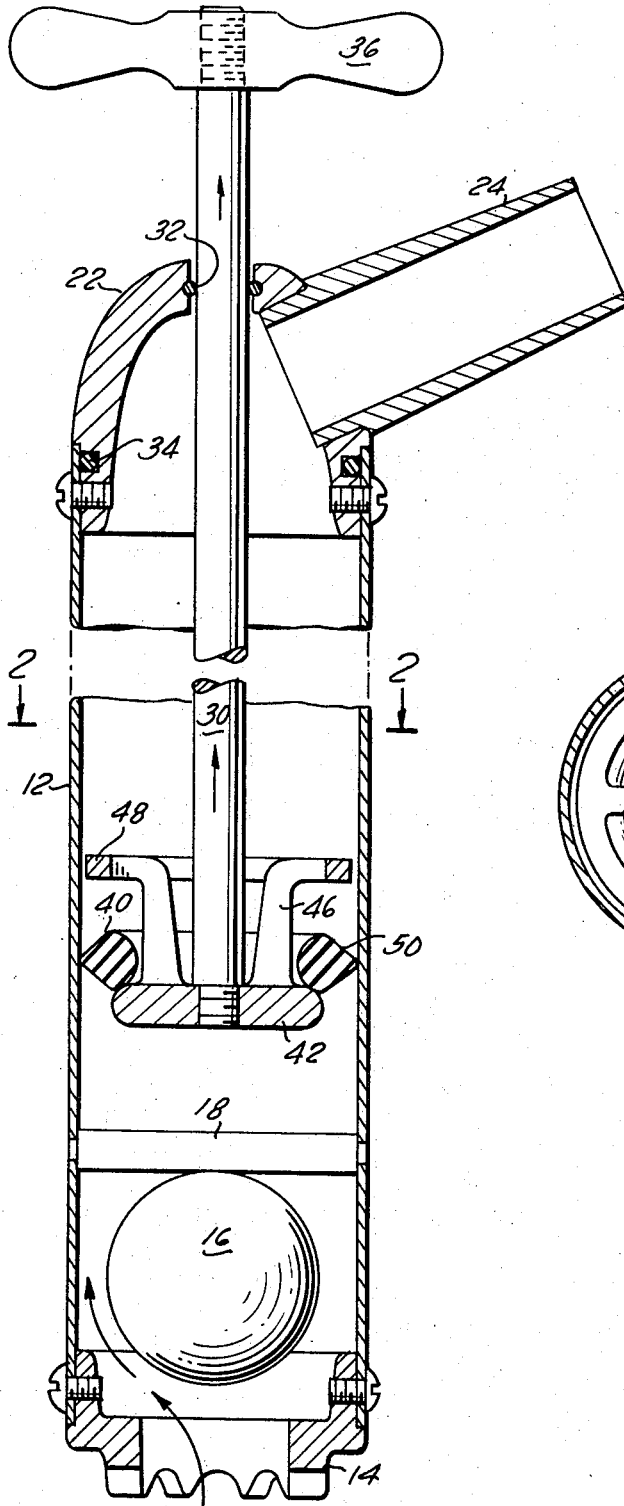

FIG. 1

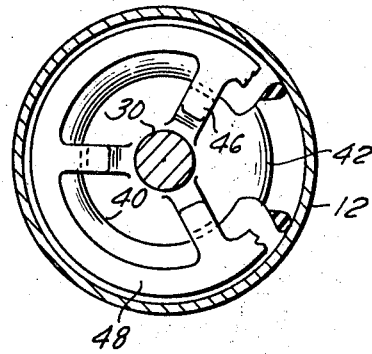

FIG. 2

L. Francis Herreshoff
INVENTOR
BY *Michael S. Stricker*
ATTORNEY

1

3,532,446

SLIDING SEAL AND VALVE FOR RECIPROCATING PUMP

L. Francis Herreshoff, Marblehead, Mass., assignor to
Margrete L. Stinnes, Jackson Heights, N.Y.

Continuation-in-part of application Ser. No. 435,307,
Feb. 25, 1965. This application Apr. 4, 1967, Ser.
No. 628,408

Int. Cl. F04b 21/04; B61f 15/22

U.S. Cl. 417—511

9 Claims

ABSTRACT OF THE DISCLOSURE

A pump for liquids including a substantial cylindrical barrel and a reciprocating pump piston located in the barrel and having combined sealing and check valve means comprising an annulus of resilient material in peripheral sliding engagement with the interior of the barrel and a piston cage loosely confining the annulus for limited axial movement relative to the cage, and in which the annulus has a cross-section forming a flexible ridge engaging the inner surface of the barrel so that differences in the diameter of the inner surface may be compensated by twisting the ridge.

CROSS-REFERENCE TO RELATED APPLICATION

The present application is a continuation-in-part application of the application Ser. No. 435,307 filed by the same inventor with the same title on Feb. 25, 1965, and now Pat. No. 3,319,577.

BACKGROUND OF THE INVENTION

The present invention relates to pumps and more particularly to reciprocating pumps such as hand operated bilge pumps for boats. The invention is concerned with improvements in the plunger or piston of such pumps and especially with the improvement residing in the sealing ring of the plunger.

In conventional types of simple reciprocating pumps, such as employed for pumping out the bilge of a boat, the piston or plunger which is reciprocated within the pump barrel may employ a cup-shaped element of leather or resilient material to provide a sliding seal between plunger and barrel. In some instances, this cup-shaped element may also serve as a valve, with the walls of the cup yielding inwardly on the downward stroke to enable liquid to flow upwardly between the cup and the barrel. On the upstroke, the walls of the cup, under the weight of liquid above, move outwardly into contact with the barrel to provide a sliding seal. Alternatively, there may be included within the pump plunger a separate check valve which opens on the down stroke and closes on the upstroke, leaving the cup-shaped member to function solely as a sliding seal between piston and barrel.

In either of these commonly employed arrangements, there is considerable difficulty due to clogging. Foreign matter is apt to become caught between sealing surfaces and the sliding seal or in the check valve, requiring that the pump be dismantled and cleaned or temporarily operated at reduced efficiency and later cleaned.

It is an object of the present invention to overcome these difficulties connected with plunger pumps of the aforementioned kind and to provide a pump plunger or piston of novel construction and configuration, wherein a combined sliding seal and check valve is employed in a manner that provides a relatively large flow capacity and is substantially free from clogging by foreign matter.

Another difficulty residing in manufacturing pumps of the aforementioned kind is to provide for a proper

2

sliding seal regardless of small variations in the diameter of the pump barrel which may especially occur in mass fabrication of pumps of this type, especially when the pump barrel is formed by an extruded plastic tube.

It is especially an object of the present invention to provide for a sliding seal which is constructed and arranged to automatically compensate for small variations in the diameter of the pump barrel.

SUMMARY OF THE INVENTION

With these objects in view, the present invention is directed on the one hand to a pump for liquids including a substantially cylindrical barrel, a reciprocated plunger rod member in the barrel, a pump piston fixed to the rod member and having combined sealing and check valve means comprising an annulus of resilient material in peripheral sliding engagement with the interior of the pump barrel, and a piston cage loosely confining the annulus for limited axial movement relative to the cage, the cage including an annular stop, a disc member against which the annulus seats on the suction stroke of the pump, the disc member having a diameter approximating the mean diameter of the annulus, and supporting arms secured at one end to the annular stop and at the other end to one of the aforementioned members for supporting the annulus in spaced relation to the disc member during the reverse stroke of the pump, the annulus having a cross section forming a flexible ridge engaging the inner surface of the barrel so that differences in the diameter of the inner barrel surface may be compensated by twisting the ridge.

On the other hand, the present invention is directed to an article of manufacture in the form of an annulus of flexible material for sealingly engaging a cylindrical surface, in which the annulus has a cross section tapering into a flexible ridge adapted to engage the cylindrical surface, so that differences in the diameter of the cylindrical surface may be compensated by twisting the ridge.

The novel features which are considered a characteristic for the invention are set forth in particular in the appended claims. The invention itself, however, both as to its construction and its method of operation, together with additional objects and advantages thereof, will be best understood from the following description of specific embodiments when read in connection with the accompanying drawings.

BRIEF DESCRIPTION OF THE DRAWING

FIG. 1 is an axial cross section through a pump according to the present invention;

FIG. 2 is a transverse cross section taken along the line 2—2 of FIG. 1;

FIGS. 3—5 schematically illustrate the engagement of the flexible annulus with inner surfaces of pump barrels having slightly different diameters (in FIGS. 3—5 the other elements of the pump are omitted for reasons of simplification); and

FIGS. 6—9 are partial cross-sectional views illustrating various shapes of the cross section of the annulus drawn on an enlarged scale.

DESCRIPTION OF THE PREFERRED EMBODIMENTS

FIGS. 1 and 2 illustrate the present invention embodied in a hand operated reciprocating pump of a type suitable for removing water from the bilge of a boat. The pump may comprise a cylindrical barrel 12 having at its bottom end a centrally open fitting 14 which serves as the pump inlet and also provides a seat for the check valve ball 16.

A rod 18 extends across the barrel as a retainer for the

ball to limit upward movement thereof as shown in FIG. 1.

At the top of the barrel, a bonnet 22 is provided with an outlet passage through sleeve 24, to which a suitable length of hose may be attached. A plunger rod 30 extends through the bonnet into the barrel, with resilient seal ring 32 to prevent leakage. Preferably a resilient seal ring 34 is also employed between the bonnet and the top end of the pump barrel 12. A suitable handle 36 is secured to the upper end of the plunger rod 30.

To enable the pump quickly to remove a relatively large volume of water with a minimum of effort on the part of the operator, a unitary pump piston and valve structure is provided, that is distinguished by large, unobstructed flow passage on the downstroke of the pump, and effective sealing with low friction on the lifting stroke. The pump piston fixed to the rod 30 has combined sealing and check valve means comprising a sealing ring or annulus of resilient material 40 which functions both as a sliding seal and as a check valve, opening on the down stroke and closing on the upstroke.

The pump piston comprises further a piston cage loosely confining the annulus 40 for limited axial movement relative to the cage. The cage includes an annular stop 48, and a disc 42 against which the annulus 40 seats on the upward suction stroke of the pump. The disc 42 is secured to the lower end of the rod and has a diameter substantially smaller than the pump barrel 12, so that an annular passage of a substantial total area is available for fluid flow around the disc on the downstroke of the pump. In general, the diameter of the disc may approximate the mean diameter of the sealing ring or annulus 40. Preferably, the disc 42 will be no larger in size than is necessary to insure that the sealing ring 40 cannot slip downwardly past the disc during pumping, nor become wedged in such a manner as to create excessive sliding friction with the pump barrel.

To take full advantage of the relatively large annular flow passage between the pump barrel and the periphery of the disc 42, the piston structure permits the resilient annulus 40 during the pump's downstroke to move axially a substantial distance away from the disc and also permits relative unobstructed flow through the open center of the annulus. To permit such axial movement of the annulus 40, the annular stop 48 is connected to the disc 42 by a small number, for instance 3, of independent supporting arms secured at one end to the annular stop 48 and at the other end to the disc 42, which arms 48 are, as clearly shown in FIG. 2 spaced from each other a distance substantially greater than the width of the arms. The length of the arms is preferably such so as to permit the sealing ring or annulus 40 to move during the pressure stroke of the pump, at which the annulus will abut against the annular stop member 48, to move away from the disc 42 far enough to provide a passage between the disc 42 and sealing ring 40 approximating the axial width of the sealing ring. As a consequence, the area of the passage between disc and seal may readily be made at least as large as the area of the annular passage between the edge of the disc 42 and the inner surface of the pump barrel 12.

According to the present invention the cross-section of the resilient annulus 40 is not circular, but the annulus 40 has a cross-section tapering into a flexible ridge 50 engaging the inner surface of the barrel 12.

Annuli or sealing rings of various cross-sections are respectively shown in FIGS. 6-9 which may be used in connection with the pump piston and cage above described.

The annulus 40a shown in FIG. 6 has on the side thereof facing away from the inner surface of the barrel 12 a substantially semicircular cross-section and is provided on the side thereof facing the inner surface of the barrel with a pair of flattened regions 52 so that the cross-section tapers from the largest diameter thereof into flexi-

ble ridge 50a which ends in a substantially sharp edge 54. The sealing rings 40b and 40c respectively shown in FIGS. 7 and 8 likewise have on the sides thereof facing away from the inner surface of the barrel a substantially semicircular cross-section and this cross-section tapers towards the inner surface of the barrel to form respectively flexible ridges 50b and 50c which have however rounded edges 56. The cross-section of the sealing ring 40c shown in FIG. 8 is symmetrical with respect to a plane of symmetry passing through the largest diameter of the sealing ring, whereas the cross-section of the sealing ring 40b as shown in FIG. 7 is slightly asymmetrical with regard to this plane in that the ridge 50b has a substantially flat region 52 at one side and a slightly curved region 53 at the other side. The sealing ring 40d shown in FIG. 9 has a cross-section which tapers from the largest width of the ring to opposite sides so as to form a pair of flexible ridges 50c ending in rounded edges 56.

Due to the specific cross-section of the sealing ring according to the present invention, the sealing ring can be used with cylinders or pump barrels of slightly different diameters while maintaining its circular outline so as to be in perfect sealing engagement with the inner surface of the pump barrel. FIG. 3 shows the arrangement of a sealing ring 40 in a pump barrel 12 having an inner diameter D_1 which is substantially equal to the outer diameter of the sealing ring. FIG. 4 shows the same sealing ring in a pump barrel having an inner diameter D_2 which is slightly smaller than the outer diameter of the sealing ring in unstressed condition. In this case, when the sealing ring, when moved by engagement with the disc 42 of the piston cage above described and not shown in FIG. 4 in the direction of the arrow indicated in FIG. 4, will twist slightly, that is the flexible ridge 50 will be deformed as shown in FIG. 4, but obviously the sealing ring will still maintain its circular outline so as to be about its whole circumference in proper sealing engagement with the inner surface of the pump barrel. FIG. 5 shows a further arrangement in which the inner diameter of the pump barrel D_3 is further reduced and in which the flexible ridge of the sealing ring is further twisted so that the flat side 52 of the ridge is nearly parallel to the inner surface of the barrel. The same sealing ring may therefore be used with barrels having diameters varying between the diameter D_1 and D_3 .

In manufacturing the pump barrel and the sealing ring cooperating therewith it will be advantageous to manufacture the inner diameter of the barrel to a theoretical value slightly smaller than the outer diameter of the sealing ring in unstressed condition so as to obtain a proper seal regardless whether the manufacturing tolerances of the inner diameter of the barrel are on the plus or on the minus side. The specific cross-section of the sealing ring will be especially advantageous when the barrel is made by extruding a plastic tube, since in extruding plastic material it is very difficult to maintain extremely close tolerances.

The operation of the pump above described will be obvious from the description thereof. On the upward stroke, the parts are as shown in FIG. 1 with the sealing ring 40 in engagement with the disc 42 to provide a substantially fluid tight sliding piston and the upward or suction stroke of which serves to draw water into the pump barrel past the open check valve at the bottom. At the reversal of the stroke, the ball 16 drops to close the check valve at the inlet and prevents the escape of water from the barrel. As the pump rod starts its downward movement, the piston cage lowers freely through the sealing ring which tends to remain stationary with respect to the pump barrel until engaged by the stop 48 of the cage. Upon continued downward movement of the piston, the sealing ring 40 will be carried along by the annular stop 48 with the water below the piston flowing freely around the disc 42 then inwardly between the disc and the sealing ring and upwardly through the seal-

ing ring into the open region above the piston. With the next upward stroke of the pump, the water above the piston is ejected through the discharge spout 24, while the barrel below the piston is filling, as before.

By reason of the relatively open structure of the piston cage and the large area of the flow passages provided, the pump has little tendency to clog. Should any chip or other foreign matter likely to be present in the bilge water get caught between the sealing ring 40 and the disc 42 at the beginning of an upstroke, such obstruction will almost always be flushed free by the rush of water through the piston as soon as the check valve opens on the following downstroke.

The flow passages of the pump are so substantial in area and so free from obstructions that the pump, when used as a bilge pump for boats, is not only much easier to operate than conventional pumps of comparable barrel size but is notably free from clogging. By the specific construction of the cross-section of the sealing ring, the sealing action of the latter is improved as compared with sealing rings of circular cross-section, and the manufacturing of the pump is facilitated in that the sealing ring according to the present invention will provide a proper seal without the necessity of maintaining the inner surface of the barrel at close tolerances.

It will be understood that each of the elements described above, or two or more together, may also find a useful application in other types of pumps differing from the types described above.

Evidently, the sealing ring according to the present invention may also be used not only in pumps but in other arrangements in which a proper seal has to be provided on a cylindrical surface.

What is claimed is:

1. A pump for liquids, comprising in combination, a substantially cylindrical barrel; a reciprocable plunger rod member in said barrel; and a pump piston fixed to said rod member and having combined sealing and check valve means comprising an annulus of resilient material in peripheral sliding engagement with the inner surface of said pump barrel, and a piston cage loosely confining said annulus for limited axial movement relative to said cage, said cage including an annular stop, a disc member against which said annulus seats on the suction stroke of the pump, the disc member having an outer diameter approximating the mean diameter of said annulus, and supporting arms secured at one end to said annular stop and at the other end to one of said members for supporting said annulus in spaced relation to

said disc member during the reverse stroke of the pump, said annulus having a cross-section forming a flexible ridge engaging the inner surface of said barrel so that differences in the diameter of said inner surface may be compensated by twisting said ridge.

2. A pump as defined in claim 1, wherein said cross-section of said annulus tapers into a flexible ridge engaging the inner surface of said barrel.

3. A pump as defined in claim 2, wherein said cross-section of said annulus is substantially semicircular on the side thereof facing away from said inner surface and tapers from the largest diameter of said cross-section into a flexible ridge engaging the inner surface of said barrel.

4. A pump as defined in claim 3, wherein said ridge has a rounded edge.

5. A pump as defined in claim 3, wherein said ridge has a substantially sharp edge.

6. A pump according to claim 1, wherein said annulus has a cross-section tapering into a flexible ridge engaging said inner surface of said barrel so that differences in the diameter of said inner surface may be compensated for by twisting said ridge and said annulus having opposite said flexible ridge a rounded surface.

7. A pump according to claim 1, wherein the flexible ridge of said annulus has a rounded edge.

8. A pump according to claim 1, wherein said flexible ridge of said annulus has a substantially sharp edge.

9. A pump according to claim 1, wherein said annulus has a cross-section tapering from its largest width to opposite sides into flexible ridges.

References Cited

UNITED STATES PATENTS

2,360,085	10/1944	Thompson	-----	103—178 X
2,444,119	6/1948	Thor'n et al.	-----	277—177
2,783,068	2/1957	Bloom et al.	-----	277—177

FOREIGN PATENTS

1,354,369	1/1964	France.
1,147,898	4/1963	Germany.
928,876	6/1963	Great Britain.
417,250	1/1967	Switzerland.

LAVERNE D. GEIGER, Primary Examiner

J. S. MEDNICK, Assistant Examiner

U.S. Cl. X.R.

277—173, 177, 207