

[54] **ANCHOR**

[75] **Inventors:** **L. Francis Herreshoff, deceased**, late of Marblehead, Mass.; **by Muriel D. Vaughn, executrix**, Marblehead, Mass.

[73] **Assignee:** **Margarete L. Stinnes**, New York, N.Y.

[22] **Filed:** **Oct. 12, 1973**

[21] **Appl. No.:** **405,812**

[52] **U.S. Cl.** **114/207**

[51] **Int. Cl.** **B63b 21/34**

[58] **Field of Search** 114/207, 208 A, 208 R

922,137 5/1909 Hall..... 114/208 R

2,722,190 11/1955 Simhauser..... 114/207

2,748,741 6/1956 Abbott..... 114/207

3,783,815 1/1974 Towne et al. 114/207

Primary Examiner—Trygve M. Blix
Assistant Examiner—Stuart M. Goldstein
Attorney, Agent, or Firm—Michael S. Striker

[56] **References Cited**

UNITED STATES PATENTS

203,087	4/1878	Swinburne	114/208 R
212,340	2/1879	White	114/207
703,739	7/1902	Rech.....	114/207

[57] **ABSTRACT**

An anchor, especially for use with yachts, having a pair of anchor arms on one end of its shank and a stock member having a pair of arms projecting to opposite sides of the shank, in which the stock member is movable on the shank between a working position located in the region of the other end of the shank with its arms extending transverse to the anchor arms and a storing position located closely adjacent to and with its arms located substantially in one plane with the anchor arms.

10 Claims, 6 Drawing Figures

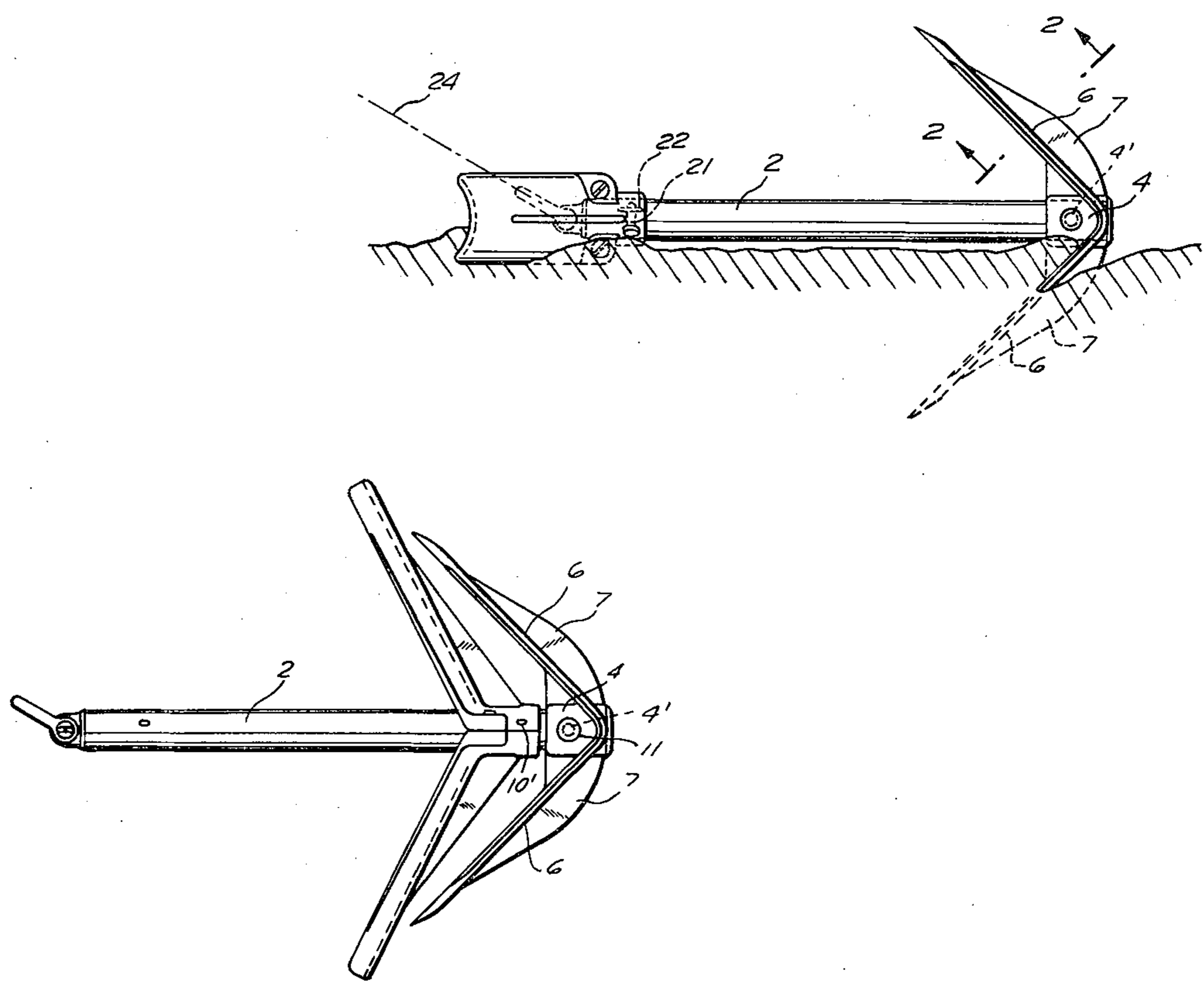

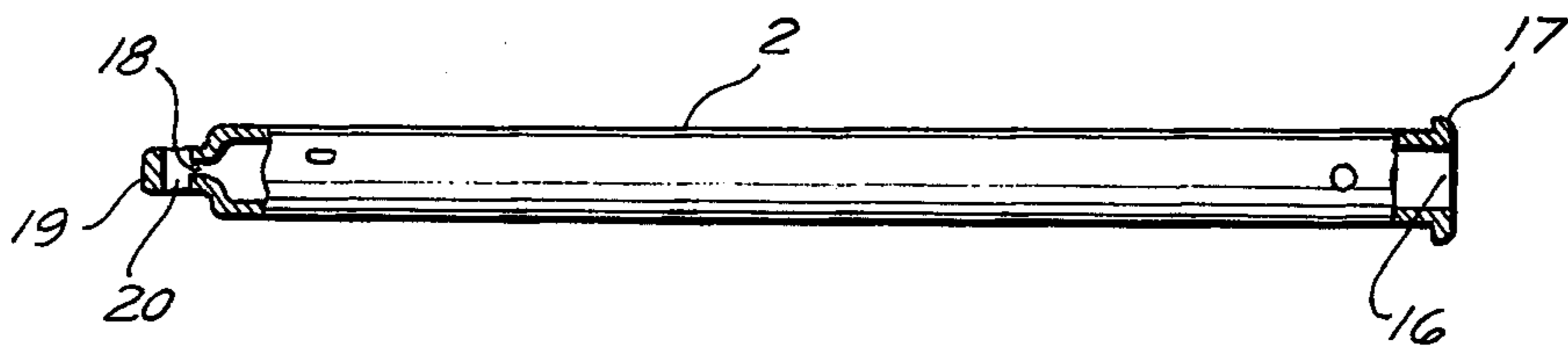
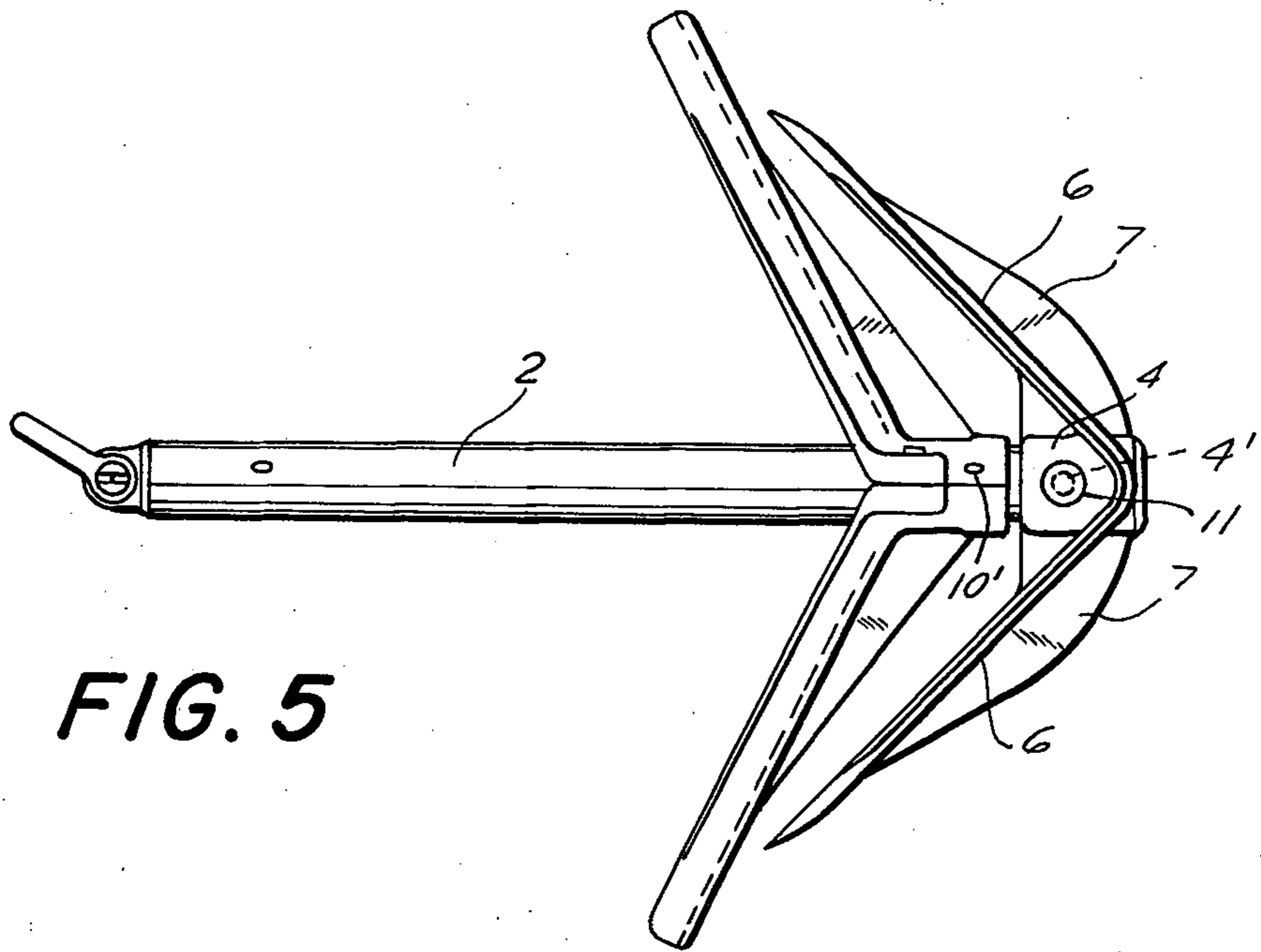
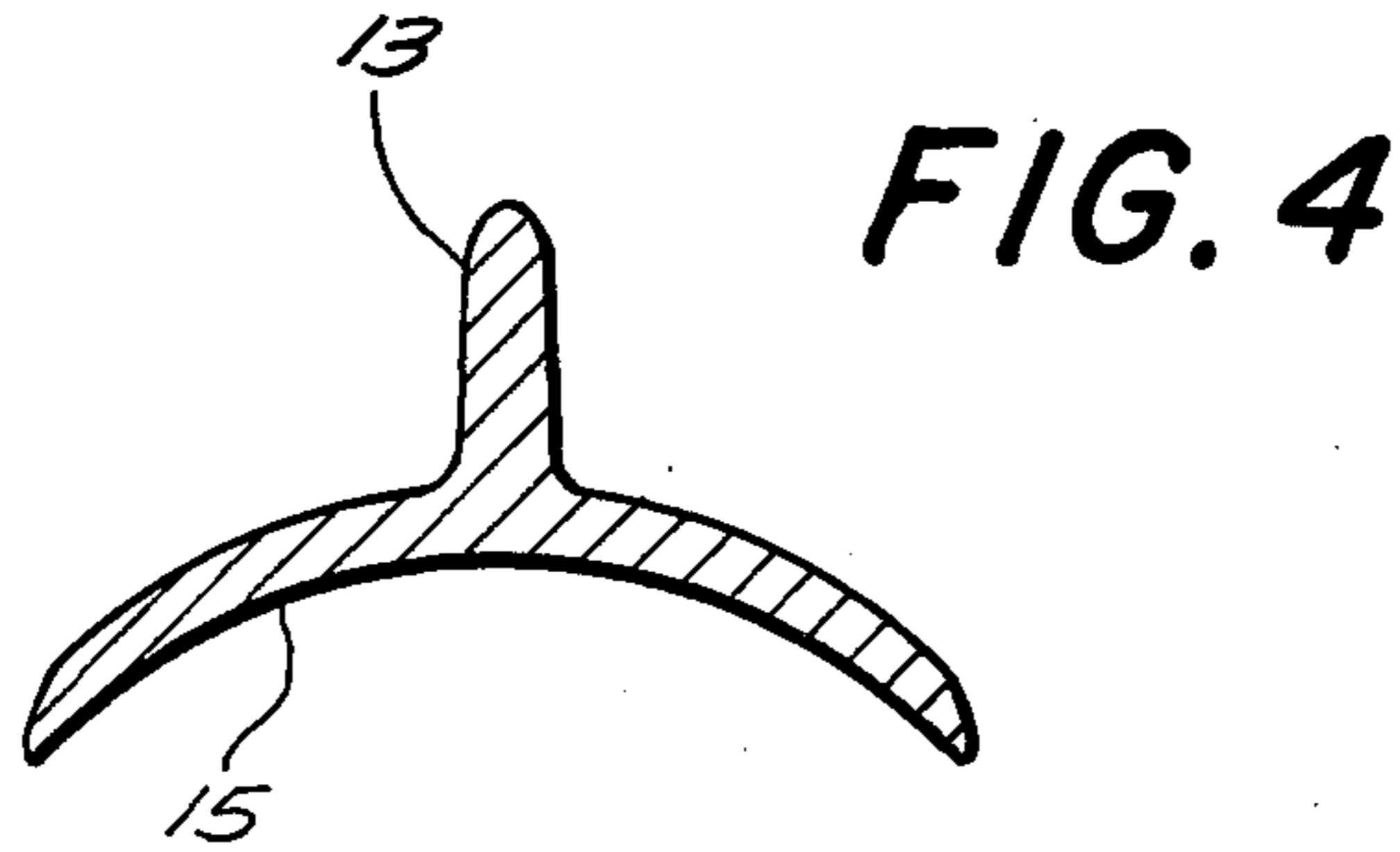

1

ANCHOR

BACKGROUND OF THE INVENTION

The present invention relates to anchors, and more specifically to anchors as used for anchoring yachts. Such anchors usually include an elongated solid shank having at one end a pair of anchor arms and, in the region of the other end to which a shackle for fastening the anchor rope to the anchor is connected, a stock member fixedly connected to the shank. Such stock member has a pair of arms extending to opposite sides of the shank and located substantially in the same plane as the anchor arms or in a plane transverse thereto. Such anchors require a relatively large storage space and the arms of the stock member contribute very little to the holding power of the anchor.

SUMMARY OF THE INVENTION

It is an object of the present invention to provide an anchor which is greatly improved over anchors known in the art.

More specifically, it is an object of the present invention to provide an anchor that requires less storage space than anchors known in the art.

It is a further object of the invention to provide an anchor in which the holding power of the anchor is greatly improved over that of anchors known in the art.

It is an additional object of the present invention to provide an anchor suitable for proper anchoring a yacht in crowded harbors.

With these and other objects in view, which will become evident as the description proceeds, the anchor according to the invention mainly comprises a shank, a pair of anchor arms extending inclined with respect to each other from one end of the shank to opposite sides of the latter, a shackle fastened to the other end of the shank and a stock member having a pair of arms projecting to opposite sides of the shank and being movable on the latter from a working position in which the stock member is located in the region of the other end of the shank and its arms are located substantially in a plane normal to the plane in which the anchor arms are located, and a storing position in which the arms of the stock member are located closely adjacent to and substantially in the same plane as the pair of anchor arms.

The anchor arms preferably have, with the exception of the free ends thereof, which are pointed, a substantially uniform width so as to prevent fouling of the anchor rope on the anchor arms. The arms of the stock member have preferably a concave side facing away from the one end of the shank so that the arms of the stock member may dig with one edge thereof into the ground to thus improve the holding power of the anchor.

The shank of the anchor is preferably tubular with a drain opening at the end from which the anchor arms project and a vent opening on the other end, so that as the anchor is lifted from the water, water contained in the interior of the shank will run out, thereby reducing the weight of the anchor.

The novel features which are considered as characteristic for the invention are set forth in particular in the appended claims. The invention itself, however, both as to its construction and its method of operation, together additional objects and advantages thereof, will

2

be best understood from the following description of specific embodiments when read in connection with the accompanying drawing.

BRIEF DESCRIPTION OF THE DRAWING

FIG. 1 is a side view of the anchor according to the present invention and showing the anchor engaged in the ground at the bottom of a body of water;

FIG. 2 is a cross-section taken along the line 2—2 of FIG. 1;

FIG. 3 is a top view of the anchor shown in FIG. 1;

FIG. 4 is a cross-section taken along the line 4—4 of FIG. 3;

FIG. 5 is a side view similar to that shown in FIG. 4, but showing the stock member in its storing position; and

FIG. 6 is a partially sectioned view of the shank.

DESCRIPTION OF THE PREFERRED EMBODIMENTS

Referring now to the drawing, and more specifically to FIGS. 1 and 3 of the same, it will be seen that the anchor according to the present invention comprises an elongated substantially tubular and cylindrical shank member 2 one end of which, shown in the drawing as the right end, is surrounded by a bushing 4 from which a pair of anchor arms 6 project to opposite sides. These anchor arms include an angle of approximately 90° with each other. As clearly shown in FIG. 3, the width of these arms is substantially uniform over the whole length thereof, with the exception of pointed ends 5. Each of the arms 6 is preferably provided at the bottom face thereof facing away from the left end of the shank, as viewed in the drawing, with an elongated reinforcing rib 7 so that the cross section of each arm has substantially the configuration as shown in FIG. 2. The bushing 4 is preferably provided with a bore 4' therethrough aligned with a corresponding bore in the shank and a pin 11, also called key, extends through the aligned bores to lock the bushing 4 in place. The pin 11 has preferably a pointed end portion protruding beyond the bushing and this end portion is formed with a cross bore through which a locking pin 13 extends to prevent accidental removal of the pin 11. The pins 11 and 13 are preferably connected to the bushing 4 by cables or the like to prevent loss of the same.

The anchor includes further a stock member 8 which comprises a bushing 10 slidably guided on the shank 2 and a pair of arms 12 integral with the bushing and projecting to opposite sides of the latter. The arms on the stock member include also an angle with each other which is preferably greater than 90°, for instance, as shown in the drawing, about 120°. The bushing 10 is preferably formed from two complementary parts 10a and 10b, which are connected to each other by screws 14. The bushing 10 of the stock member may be connected to the shank in the same manner as the bushing 4, i.e., the bushing parts 10a, 10b are formed with aligned bores 10' which are aligned in the position of the stock member shown in shown in FIGS. 1 and 3 with a corresponding bore through the shank 2 and a pin 21 extending through the aligned bores holds the stock member 3 in the desired position. At its protruding end portion the pin is preferably provided with a cross bore through which a locking pin 22 extends to prevent accidental removal of the pin 21 from the bores. The pins 21 and 22 are preferably fastened to the stock member

8 by cables or the like. When the pin 21 is withdrawn from the bores the stock member can be brought from the working position as shown in FIG. 3 to a storing position as shown in FIG. 5, in which the arms 12 of the stock member are located closely adjacent to the anchor arms 6 and substantially in the same plane as the latter. The front face 15, i.e., the left face as viewed in the drawing, of each arm 12 of the stock member is concavely curved, as best shown in the cross-section of FIG. 4, and the opposite face is preferably provided with a reinforcing rib 13.

The shank 2 is, as mentioned above, substantially tubular and provided at its end from which the anchor arms project with a drainhole 16 and at its opposite end with a small diameter central hole 18 which communicates with a transverse bore 20 formed in the small diameter solid end portion 19 of the shank. An annular rim 17 is preferably provided around the end of the shank on which the bushing 4 abuts. A substantially U-shaped shackle 23 is hingedly connected to the end portion 19 by a pin extending transversely through the bore 20.

The anchor according to the invention has the following advantages over anchors known in the art. The stock member of the anchor can be brought as described above, from its working position, as shown in FIG. 3, to a storing position, as shown in FIG. 5, whereby the storage space needed for the anchor is greatly reduced. By making the width of the anchor arms substantially uniform throughout the length thereof, with the exception of the pointed ends, the danger that the anchoring rope will be caught by the anchor arms is greatly reduced. At the same time, the holding area of the anchor arms is increased over anchor arms as commonly used in the art, in which usually the outer portions of the arms also called "palms" are wider than the portions of the arms connecting these palms to the shank. In addition, the specific construction of the anchor arms disclosed will facilitate braking loose of the anchor from the ground during lifting of the anchor since in this case the connecting portion or crown of the arms will not dig into the ground when the anchor is turned from the position shown in FIG. 1 during pulling of the anchoring rope 24 connected to the shackle during lifting of the anchor.

The specific construction of the stock member as described above, has not only the advantage that the stock member 8 can be brought from its active position as shown in FIG. 3, to its storing position as shown in FIG. 5, to thereby reduce the storing space for the anchor, but due to the curved front faces on the arms 12, the arms of the stock member will also dig into the ground, as shown in FIG. 1, which will increase the holding power of the anchor. Furthermore, since the arms 12 of the stock member include an angle with each other, the shackle 23 is displaced rearwardly with regard to the outer ends of the arms 12, which tends to hold the head of the anchor to which the shackle is attached down during the engagement of the anchor with the ground. Furthermore, the included angle between the arms of the stock member will also prevent the head of the anchor from being moved around when the anchoring rope is pulled in different directions after the anchor is engaged, which may occur when the boat connected to the anchor veers around when the direction of the wind, acting on the boat, changes.

Since the shank of the anchor is tubular with a vent hole on the top and a drainhole at the bottom, the shank will fill with water when the anchor is lowered below the surface of the water, but when the anchor is lifted above the water level, the water is drained out, so that the anchor will be easier to handle.

It will be understood that each of the elements described above, or two or more together, may also find a useful application in other types of anchors differing from the types described above.

While the invention has been illustrated and described as embodied in an anchor having a stock member movable along the shank of the anchor from a working position located in the region of the end of the shank to which the shackle for connecting the anchoring rope to the shank is located and a storing position in which the stock member is located closely adjacent to the anchor arms on the other end of the shank, it is not intended to be limited to the details shown, since various modifications and structural changes may be made without departing in any way from the spirit of the present invention.

Without further analysis, the foregoing will so fully reveal the gist of the present invention that others can be applying current knowledge readily adapt it for various applications without omitting features that, from the standpoint of prior art, fairly constitute essential characteristics of the generic or specific aspects of this invention and therefore such adaptations should and are intended to be comprehended within the meaning and range of equivalence of the following claims.

What is claimed as new and desired to be protected by Letters Patent is set forth in the appended claims:

1. An anchor comprising a shank; a pair of anchor arms extending inclined with respect to each other from one end of said shank to opposite sides of the latter; a shackle fastened to the other end of said shank; and a stock member having a pair of straight arms projecting to opposite sides of said shank and being movable on the latter from a working position in which said stock member is located in the region of said other end of said shank and its straight arms are located substantially in a plane normal to the plane in which said anchor arms are located, to a storing position in which the straight arms of the stock member are located closely adjacent to and substantially in the same plane as said pair of anchor arms, each of the straight arms of the stock member having a front face facing away from said one end of said shank and being concavely curved in a direction transverse to the longitudinal direction of the respective arm of said stock member.

2. An anchor as defined in claim 1, wherein said shank is substantially tubular having a drain opening at said one end and a vent opening at the other end.

3. An anchor as defined in claim 2, wherein said stock member comprises a bushing mounted on said shank for movement between the ends thereof, said arms of said stock member projecting to opposite sides of said bushing integral therewith.

4. An anchor as defined in claim 1, wherein said anchor arms and arms of said stock member include each a reinforcing rib extending in longitudinal direction of the respective arm.

5. An anchor as defined in claim 1, wherein said anchor arms include an angle of substantially 90° with each other.

5

6. An anchor as defined in claim 1, wherein each said arms of said stock member include an obtuse angle with each other.

7. An anchor as defined in claim 1, and including means for releasably securing said stock member in said working position to said shank.

8. An anchor as defined in claim 1, and including means for releasably connecting said anchor arms to said one end of said shank.

9. An anchor as defined in claim 1, wherein said arms of said stock member are longer than said anchor arms and are each inclined to the axis of said shank to project, in the working position of said stock member, with free ends thereof in the axial direction of said shank beyond said other end of the latter.

10. An anchor comprising a shank; a pair of anchor arms extending inclined with respect to each other from one end of said shank to opposite sides of the latter; a shackle fastened to the other end of said shank; and a stock member having a pair of arms projecting to

6

opposite sides of said shank and being movable on the latter from a working position in which said stock member is located in the region of said other end of said shank and its arms are located substantially in a plane normal to the plane in which said anchor arms are located, to a storing position in which the arms of the stock member are located closely adjacent to and substantially in the same plane as said pair of anchor arms, each of the arms of said stock member having a front face facing away from said one end of said shank and being concavely curved in a direction transverse to the longitudinal direction of the respective arm of said stock member, said stock member comprising a bushing formed of two complementary halves, said arms of said stock member being respectively integral with said halves of said bushing and projecting therefrom to opposite sides of the latter, and means for connecting said halves to each other.

* * * * *

25

30

35

40

45

50

55

60

65